

Pasul 11 (Montaj Maner)

Se monteaza pe placa (5) maner (Mn) x 1 buc cu suruburi (S4) M4x22 - 4 buc in gaurile existente pe placa.

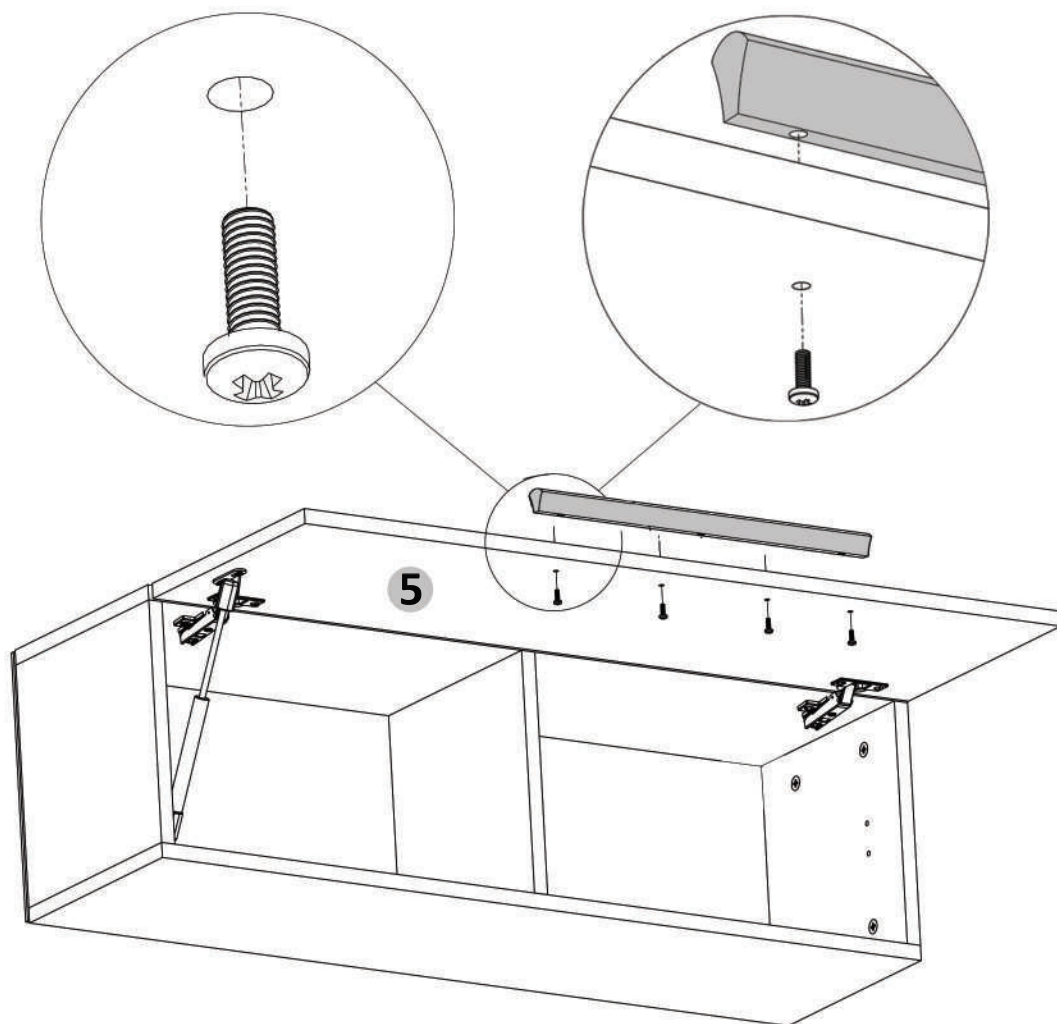

Instrucțiuni montaj: Corp Living 1200 - Pozitie Orizontala Superioara

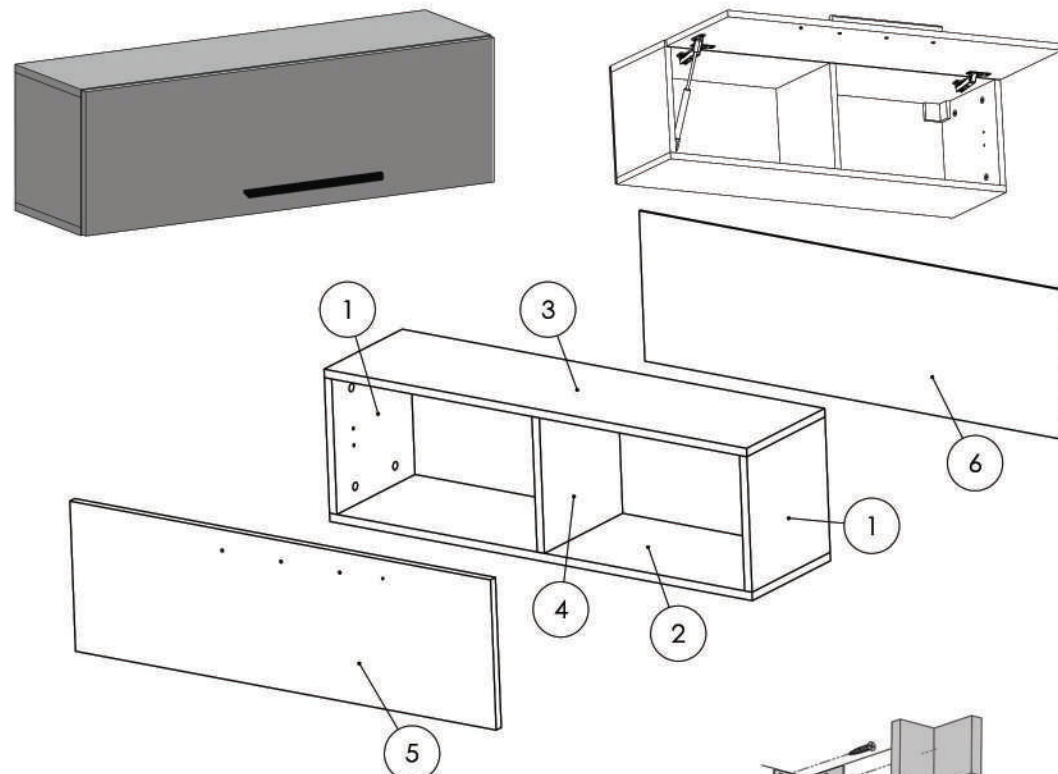

ATENȚIE: Prinderea corpurilor superioare de perete se face cu ajutorul coltarelor care trebuie montate pe corp cu (S3).

NR. REPER	DETALII	COD REPER	CANTITATE
1	PAL 268 X250X16	TAVAN / FUND	2
2	PAL1200X250X16	LATERALA DR.	1
3	PAL1200X250X16	LATERALA ST.	1
4	PAL 268 X250X16	INTERMEDIARA	1
5	PAL1196X286X16	USA	1
6	HDF1196X286X4	HDF	1

ATENȚIE: MONTAJUL NECORESPUNZĂTOR ATRAGE DUPĂ SINE PIERDEREA GARANȚIEI PRODUSULUI



Șurubelniță în cruce sau autofiletantă













Este recomandat ca montajul să fie făcut de minim două persoane



Un ciocan de dimensiune medie

Elemente feronerie pt. corp positionat orizontal superior:

DEMONTABIL CU EXCENTRIC De  12	Coltar Plastic Alb Cp  2	SURUB TIP CONFIRMATOR 4x22 S4  4	CAMA Ca  12
CUIE Cu  24	TALPA LATERALA PISTON TL  2	BALAMALE APLICATE Ba  2	SURUB 3.5X16 S3  17
PISTON Ps  2	TALPA USA PISTON TU  2	MANER 600 Mn  1	

Pasul 1 (Montaj Demontabili)

Se prinde cu infiletanta sau surubelnita 12 x (De) pe placile laterale (2) si (3).

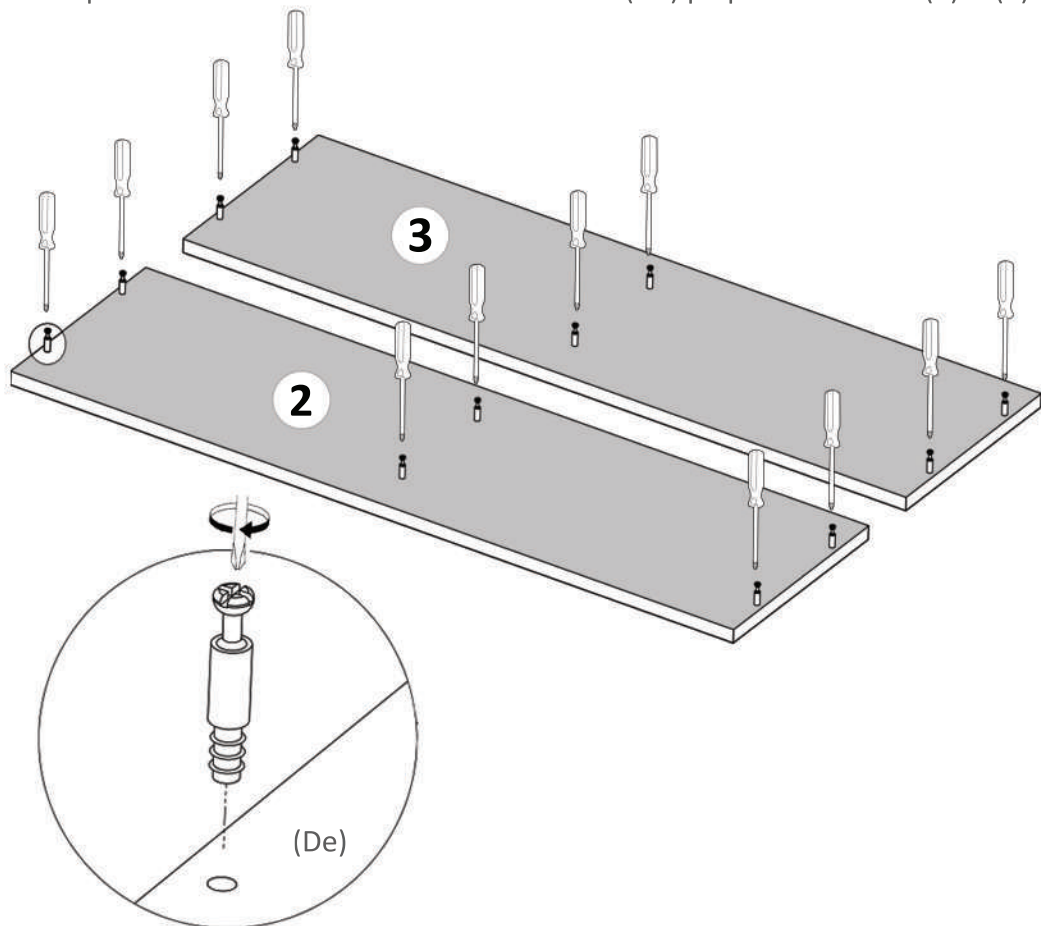

Pasul 10 (Montaj coltare)

Se monteaza pe placile (1) Coltare (Cp) x 2 buc cu suruburi (S3) 3.5x16 - 4 buc cate 2 suruburi / coltar. Aceste coltare o sa va ajute sa prindeti corpurile de perete.

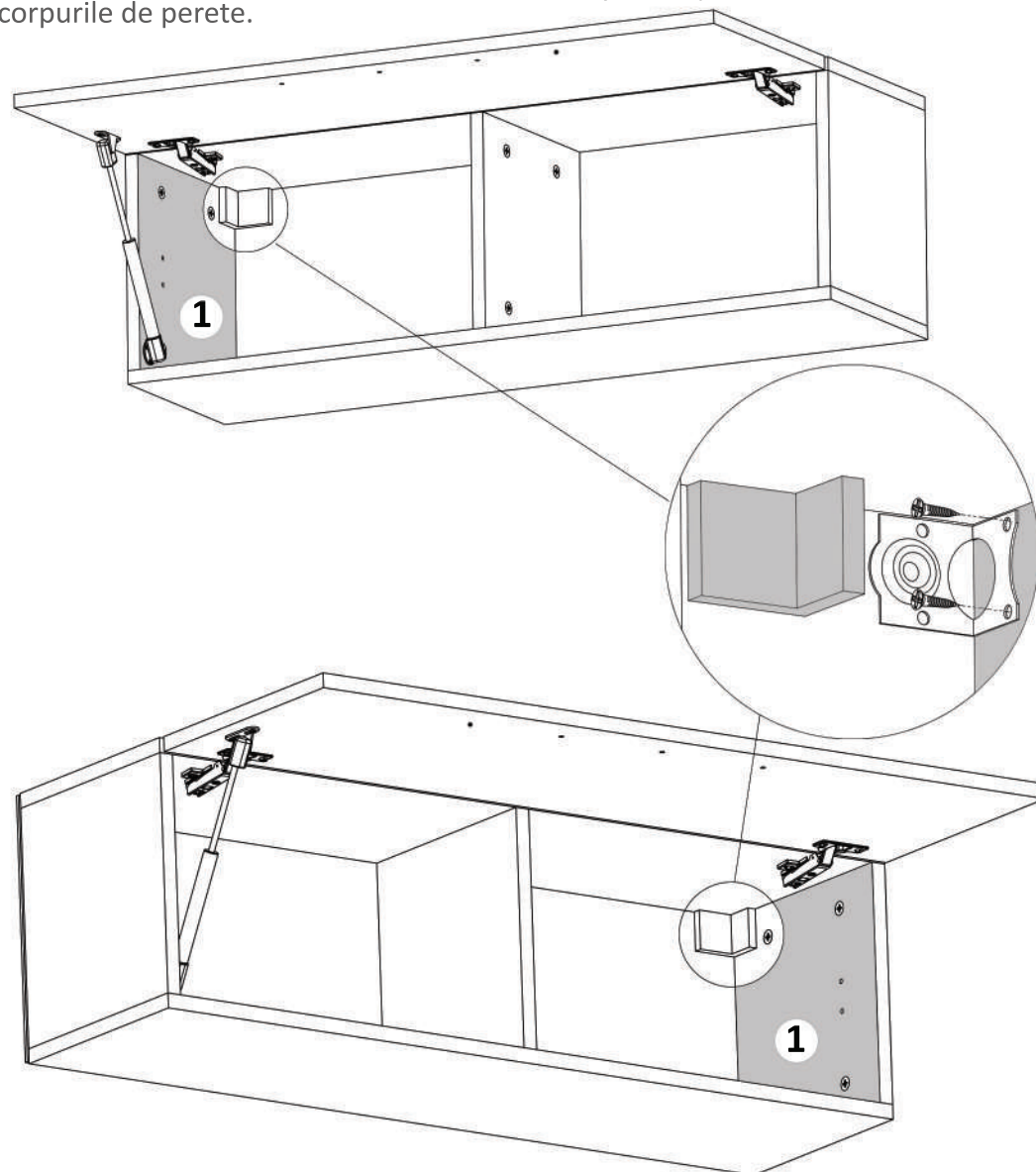

Pasul 8 (Montaj Talpa Usa Piston)

Se pozitioneaza (TU) x 1 buc pe placa (5) in locurile pe care le-ati insemnat inainte cu creionul si se prinde cu suruburi (S3) 3.5x16 -2buc.

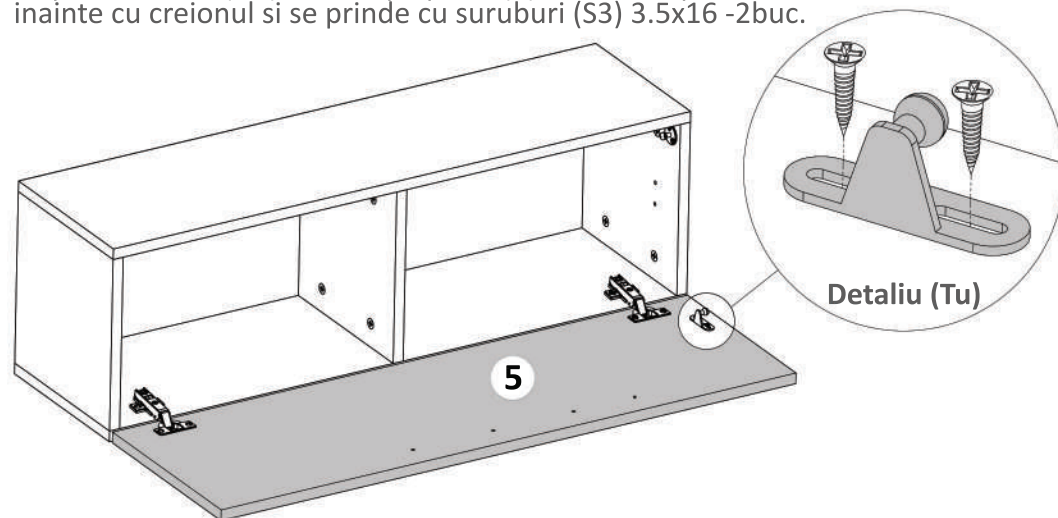

Pasul 9 (Montaj Piston)

Se monteaza (Ps) x 1 buc introducand pistonul in (TU) si (TL).

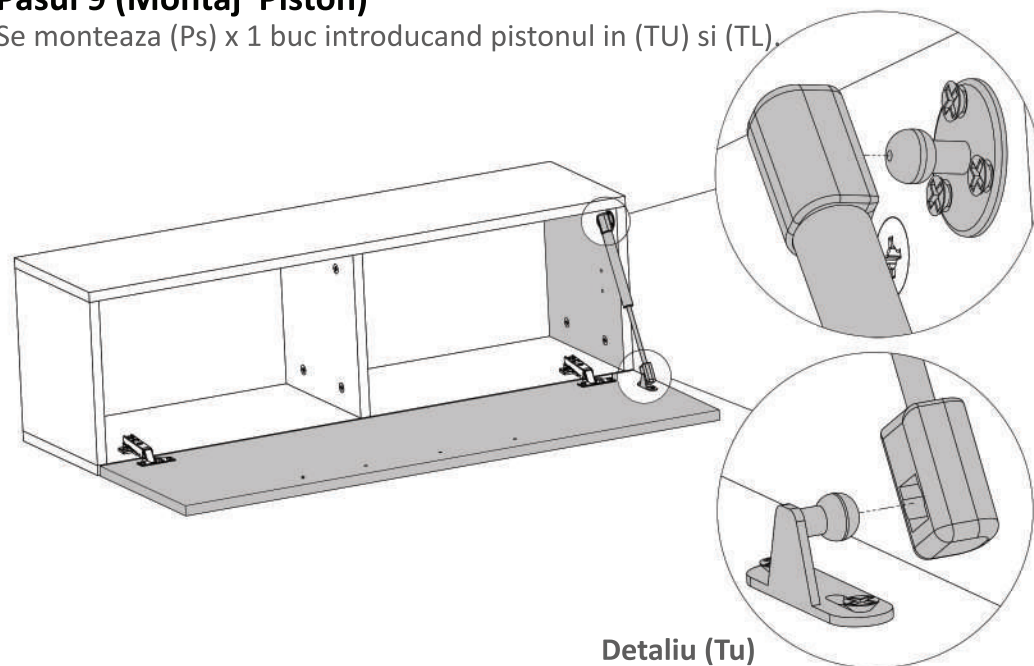

Pasul 2 (Montaj talpa laterala piston)

Se pozitioneaza (TL) x 1 buc pe placa (1) in locurile pe care le-ati insemnat inainte cu creionul si se prinde cu suruburi (S3) 3.5x16 -3buc.

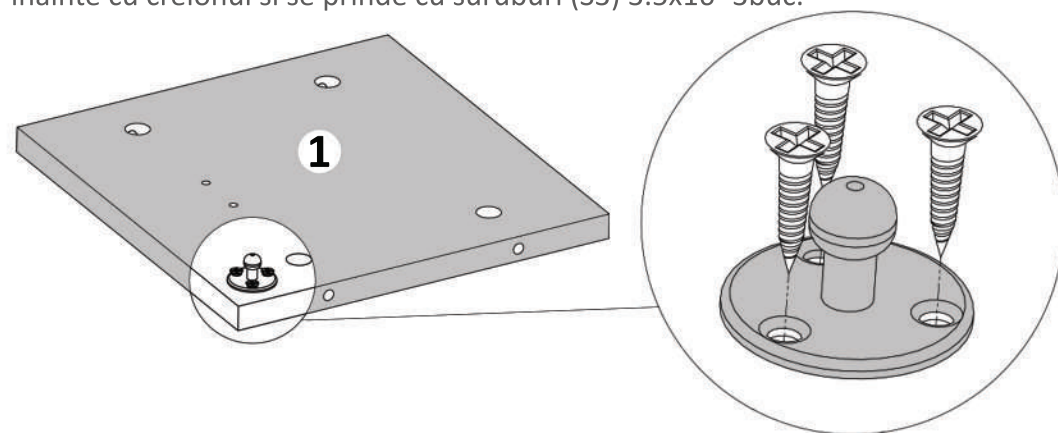

Pasul 3 (Montaj repere)

Se prind de placa laterala (3) placile (1) si (4) cu demontabili (De) x 6 buc - cate 2 buc / placa in gaurile prestabilite, urmand ca apoi sa se infiletze (Ca) x 6 buc pana raman stranse.

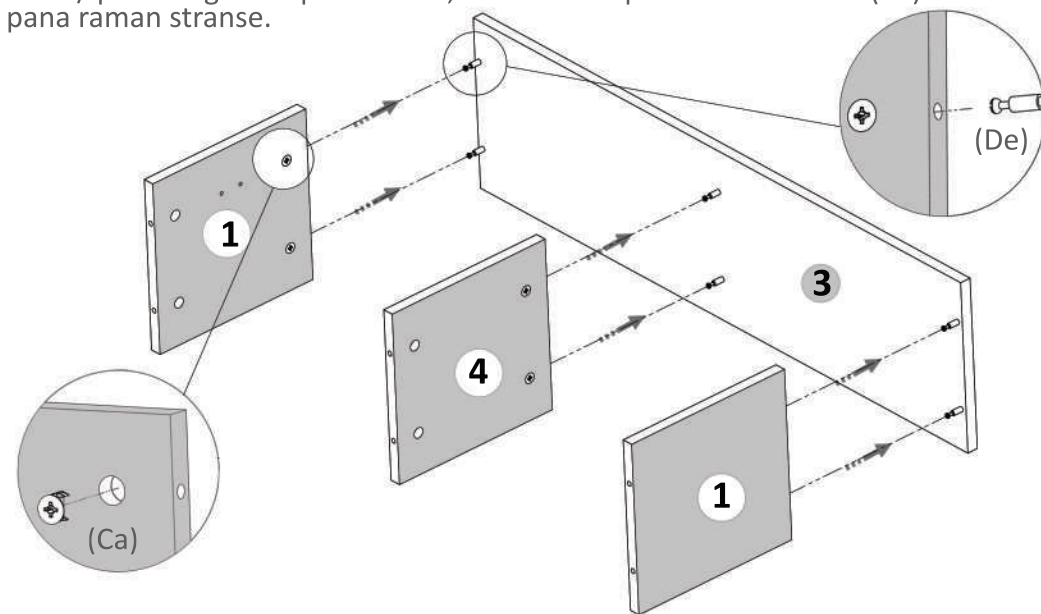

Pasul 4 (Montaj repere)

Se prinde placa laterala (2) de placile (1) si (4) cu demontabili (De) x 6 buc in gaurile prestabilite, urmand ca apoi sa se infileteze (Ca) x 6 buc pana raman stranse.

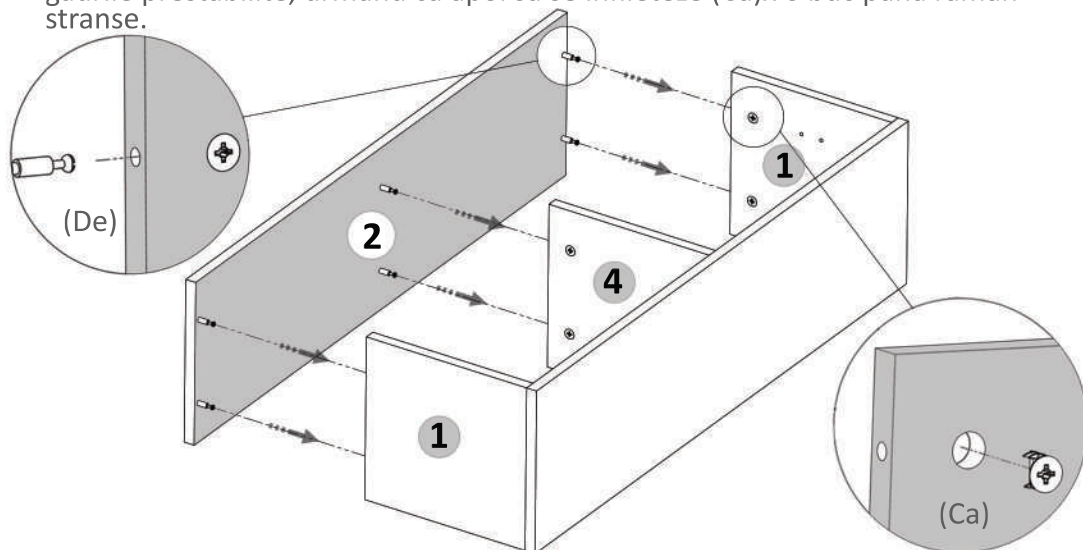

Pasul 5 (Montaj HDF)

Se masoara diagonalele sa fie in vinclu, dupa care se prinde HDF-ul (6) folosindu-se de ciocan cu ajutorul unor cuie (Cu) x 24 buc.

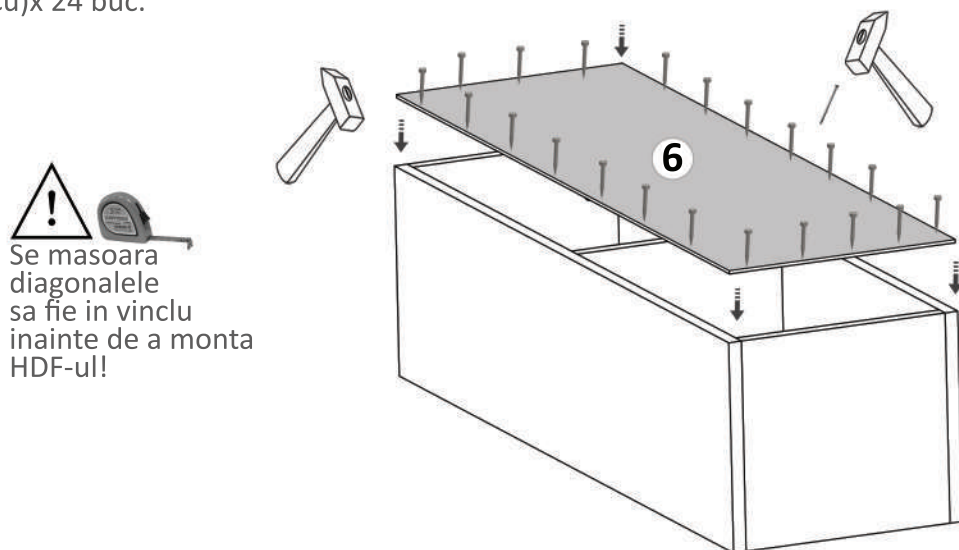

Pasul 6 (Montaj Balamale pe Usa)

Se prinde pe placa (5) balamale (Ba) x 2buc cu suruburi (S3) x 4buc, cate 2 buc / balama.

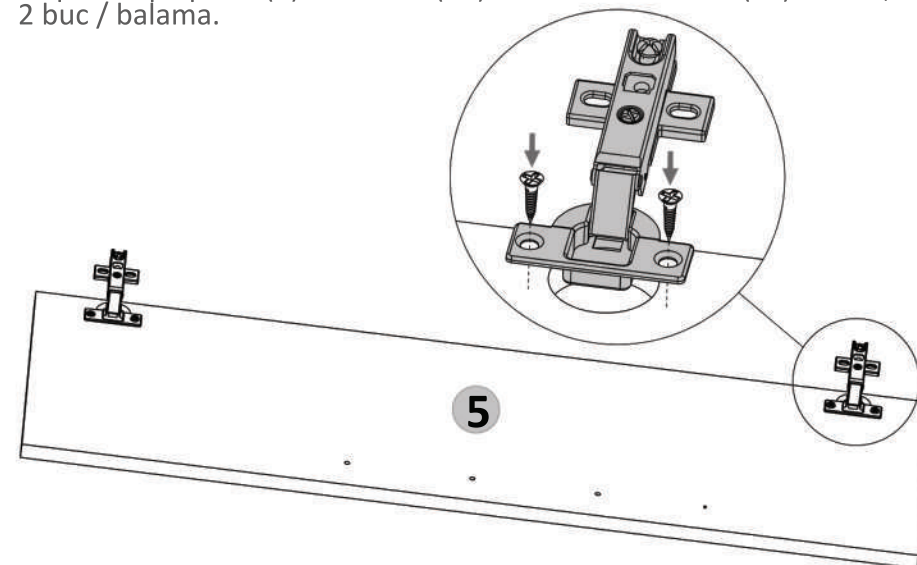

Pasul 7 (Montaj Balamale)

Se lipeste placa (5) de cantul placii (2) si se monteaza pe placa (2) balamale (Ba) x 2 buc folosindu-se suruburi 3.5x16 (S3) - cate 2 / balama.

