

Instrucțiuni montaj: **ANSAMBLU OPTIONAL CORP CU SERTARE**

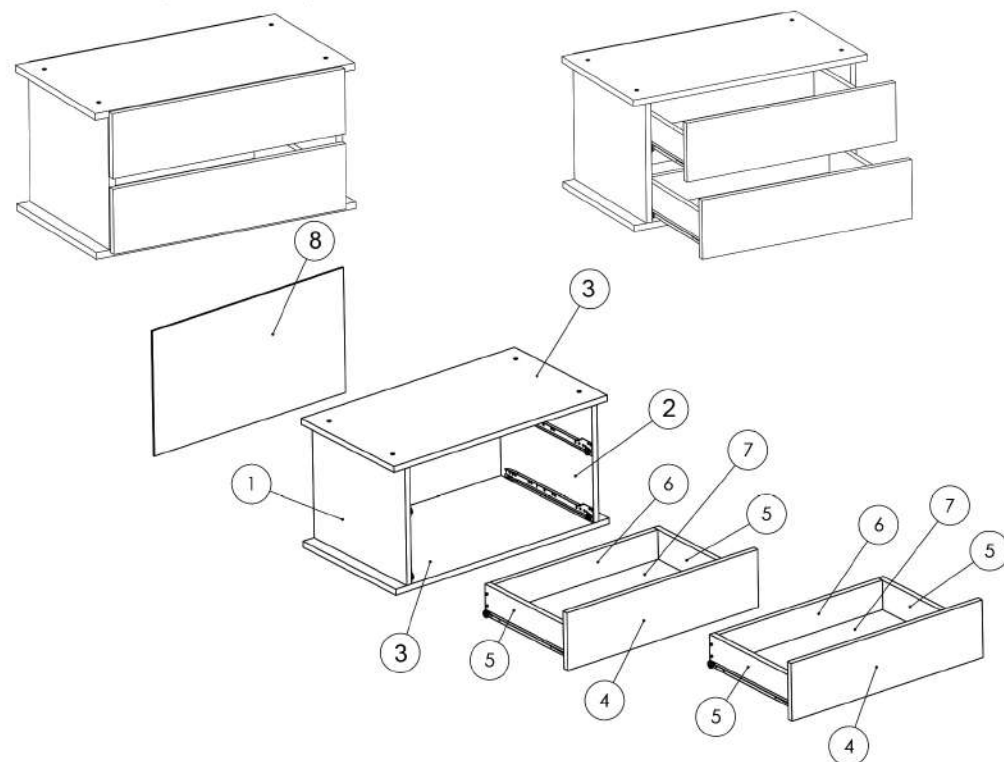

NR REPER	COD REPER	DETALII	CANTITATE
1	LATERALA STANGA	PAL 374 X 316 X 16	1
2	LATERALA DREAPTA	PAL 374 X 316 X 16	1
3	CAPAC INFERIOR / CAPAC SUPERIOR	PAL 666 X 374 X 16	2
4	FATA SERTAR	PAL 596 X 156 X 16	2
5	LATERALA SERTAR	PAL 350 X 80 X 16	4
6	CAPAT SERTAR	PAL 510 X 80 X 16	2
7	HDF SERTAR	HDF 538 X 350 X 4	2
8	HDF ANSAMBLU	HDF 596 X 338 X 4	1

ATENȚIE: MONTAJUL NECORESPUNZĂTOR ATRAGE DUPĂ SINE PIERDEREA GARANȚIEI PRODUSULUI



Șurubelniță în cruce
sau autofiletantă











Este **recomandat** ca
montajul să fie făcut de
minim două persoane

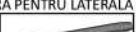
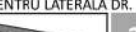
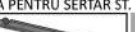

Un **ciocan** de dimensiune
medie

Elemente feronerie pentru Corpul cu sertare:

DEMONTABIL CU EXCENTRIC De  4	SURUB 3.5X30 S5  4	SURUB 3.5X40 S6  8	CAMA Ca  4
CUIE Cu  50	CONFIRMATOR 7X50 Co  8	SURUB 3.5X16 S3  16	
GLISIERA PENTRU LATERALA ST. Gs  2	GLISIERA PENTRU LATERALA DR. Gd  2	GLISIERA PENTRU SERTAR ST. GSS  2	GLISIERA PENTRU SERTAR DR. GSd  2

Pasul 1

Se prinde cu infiletanta (Gs) x 2 buc pe placa (1) si (Gd) x 2 buc pe placa (2), fiecare cu cate 2 suruburi (S3) in gaurile punctate din placa.

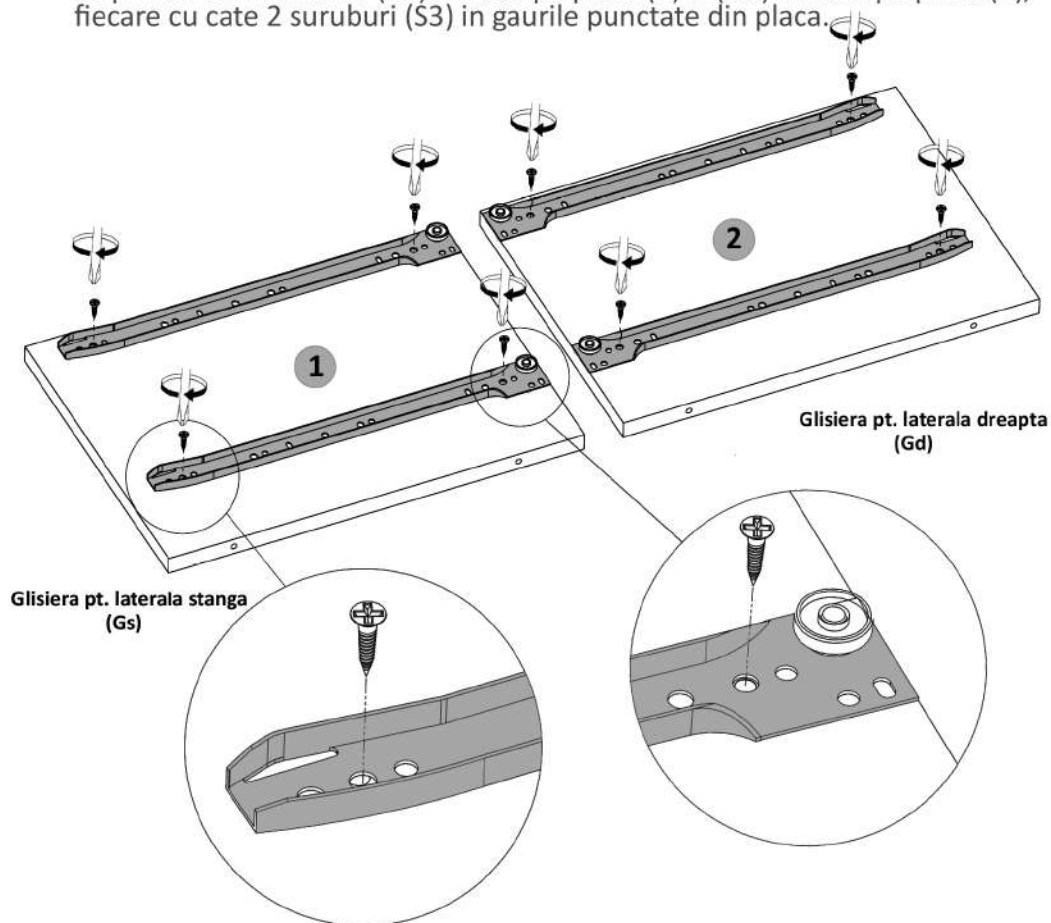

Pasul 9 (Montaj Corp cu sertare in interiorul dulapului)

(B)

Se poate monta corpul cu sertare pe polita fixa precum in imaginea din dreapta cu suruburi (S3) - 3.5x30 - 4 buc care se prind de pe placa (3) a corpului cu sertare dupa care se pun sertarele unul cate unul pe glisiera corespunzatoare fiecaruia.

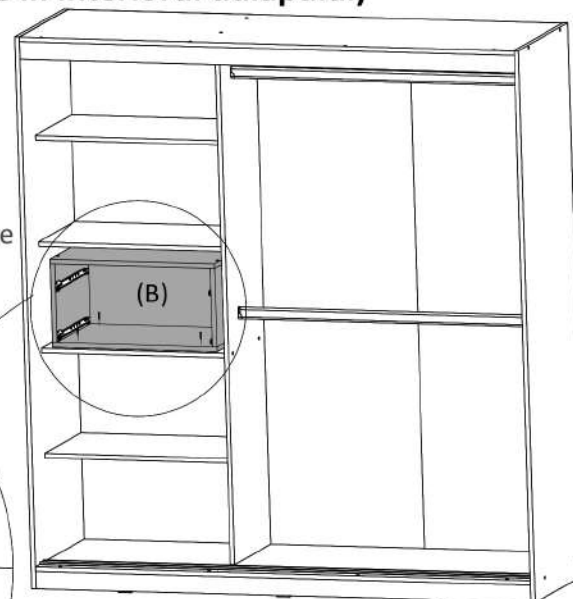
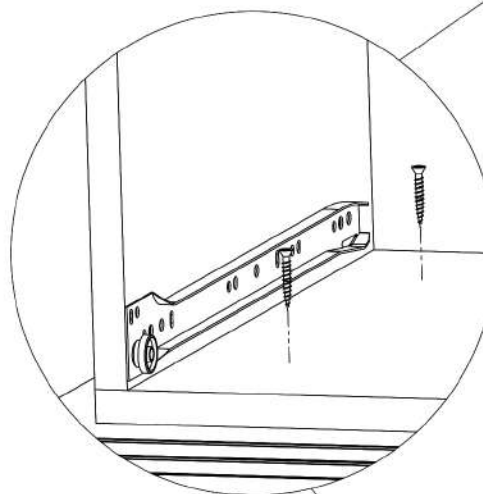

(A)

Se poate monta corpul cu sertare pe fundul dulapului precum in imaginea din dreapta cu suruburi (S3) - 3.5x30 - 4 buc care se prind de pe placa (3) a corpului cu sertare dupa care se pun sertarele unul cate unul pe glisiera corespunzatoare fiecaruia.

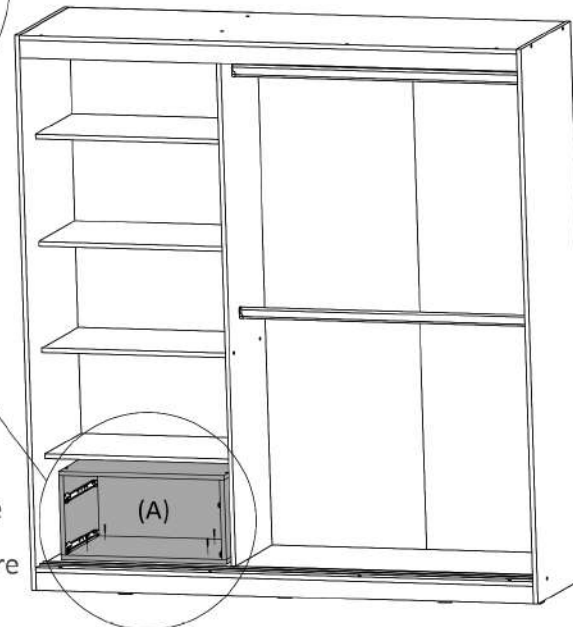

Pasul 8 (Montaj Glisiera Stanga / Dreapta Sertar)

Se monteaza pe placile (5) -1 x Glisiera pentru sertar partea dreapta (GsD) si -1 x (GsS) Glisiera pentru sertar partea stanga, cu ajutorul suruburilor (S3) 3.5x16 - cate 2 /glisiera.

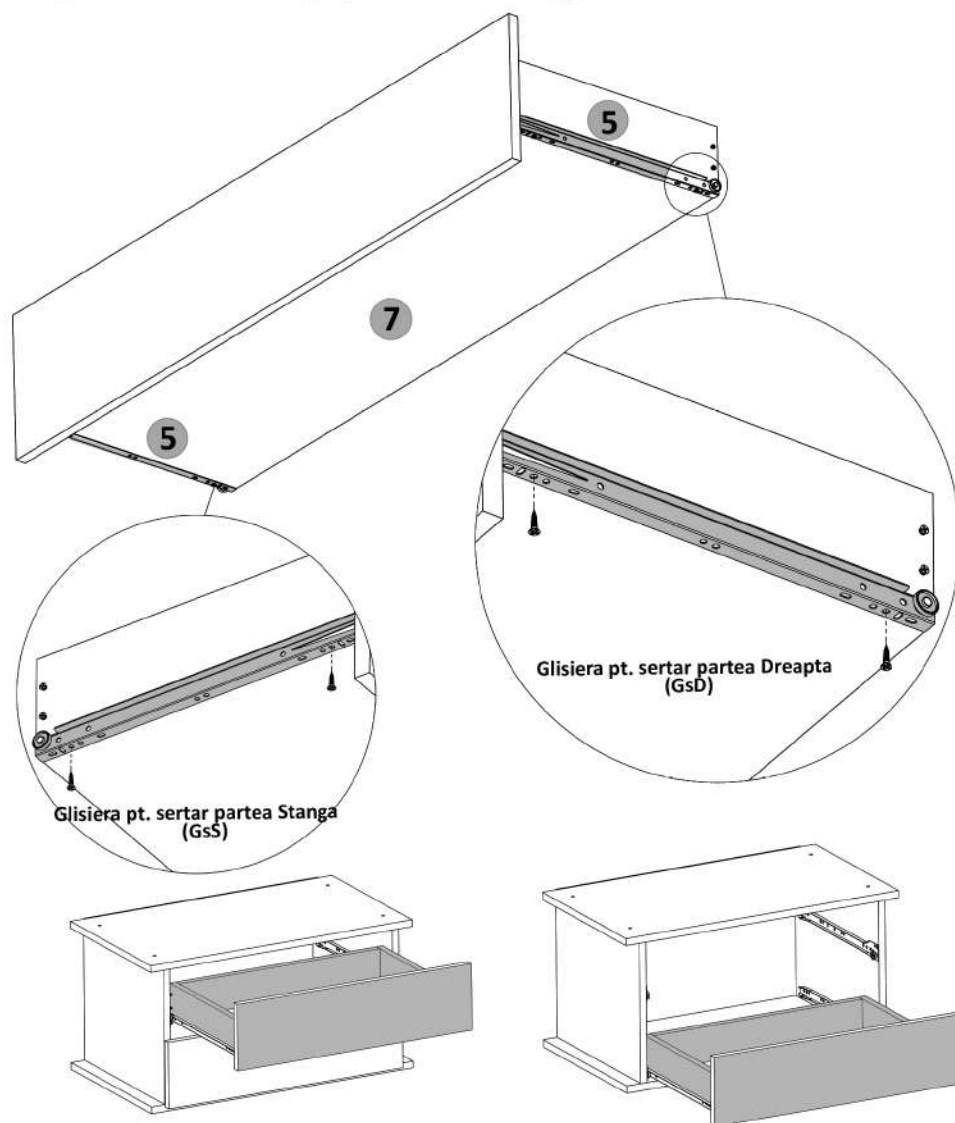

Pasul 2 (Montaj Repere)

Se prinde placa (3) de placile (1) si (2) cu Confirmatoare (Co) x 4 buc in gaurile facute pentru acestea. Prinderea se poate face atat cu masina cat si manual cu cheie Imbus.

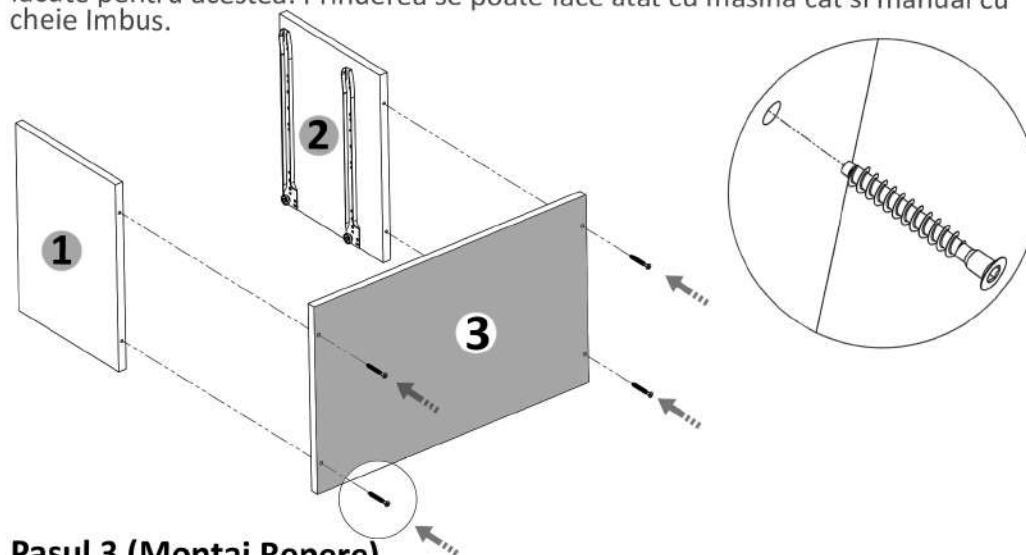

Pasul 3 (Montaj Repere)

Se prinde placa (3) de placile (1) si (2) cu Confirmatoare (Co) x 4 buc in gaurile facute pentru acestea. Prinderea se poate face atat cu masina cat si manual cu cheie Imbus.

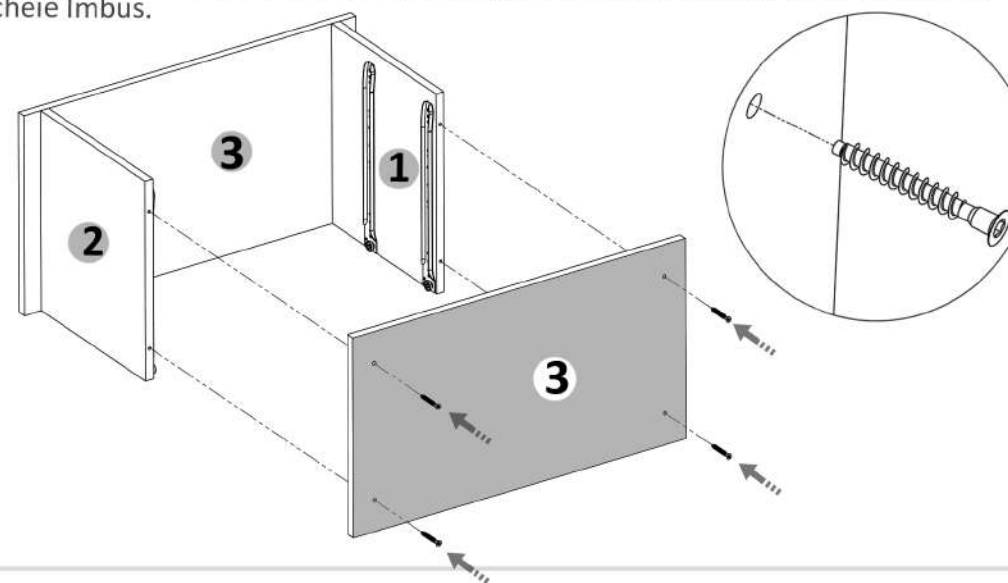

Pasul 4 (Montaj HDF)

Se masoara diagonalele sa fie in vinclu, dupa care se prinde HDF-ul (8) folosindu-se de ciocan cu ajutorul unor cuie (Cu) x 30 buc.

⚠ Se masoara diagonalele sa fie in vinclu inainte de a monta HDF-ul!

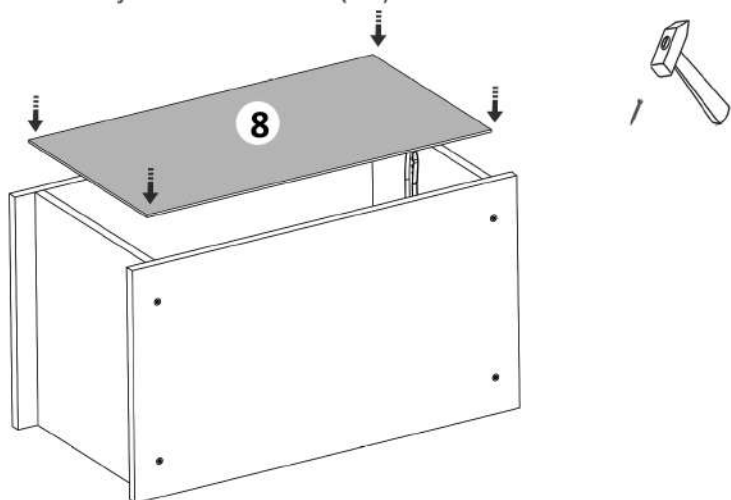

Pasul 5 (Montaj Sertare) x 2 BUC

Se monteaza placile (5) de placa (6) cu ajutorul suruburilor (S6) 3.5x40, cate 2 buc / placa, in gaurile realizate pentru acestea.

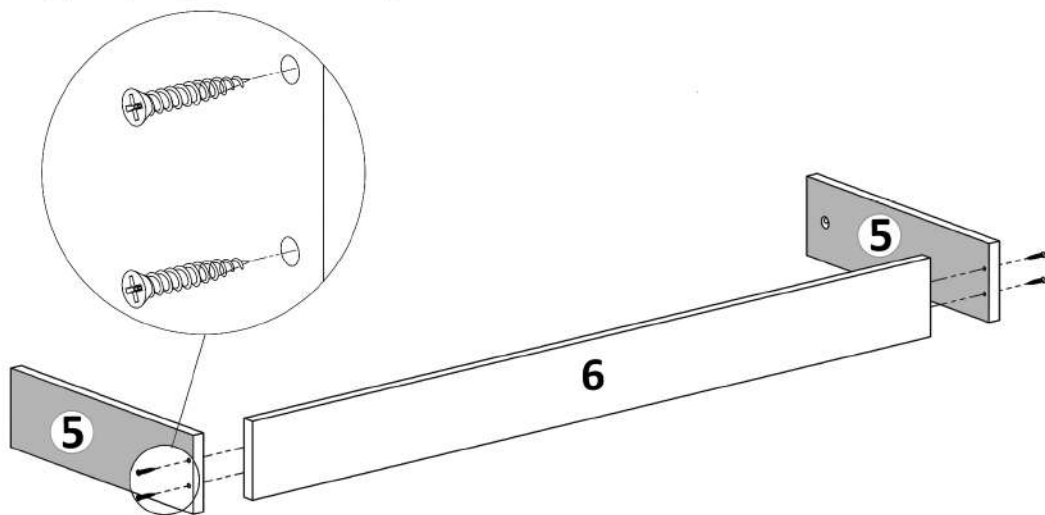

Pasul 6 (Montaj Sertare) x 2 BUC

Se prinde placa Front (4) de placile (5) cu demontabili (De) x 2 buc in gaurile prestabilite, urmand ca apoi sa se infleteze (Ca) x 2 buc pana acestea raman stranse.

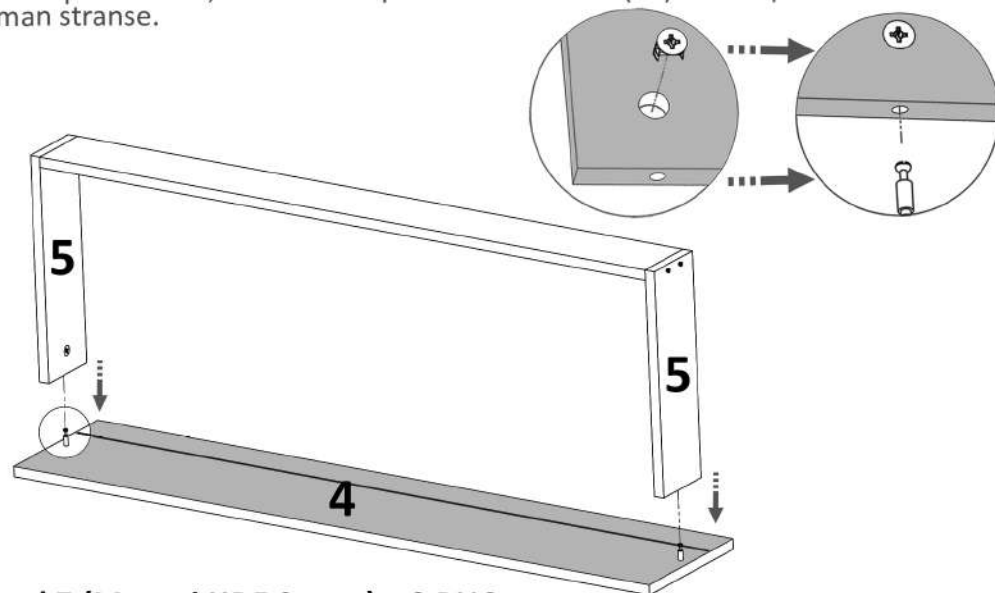

Pasul 7 (Montaj HDF Sertar) x 2 BUC

Se masoara diagonalele sa fie in vinclu, dupa care se prinde HDF-ul (7) folosindu-se de ciocan cu ajutorul unor cuie (Cu) x 20 buc. HDF-ul trebuie pozitionat si introdus in locul acestuia de pe placa (4).

⚠ Se masoara diagonalele sa fie in vinclu inainte de a monta HDF-ul!

