

## Pasul 5 (Montaj Repere)

Se prinde placa (5) cu demontabili (De) x 4 buc in gaurile prestabilite, urmand ca apoi sa se infileteze (Ca) care trebuie puse pe placa (1) x 2 buc si pe placa (2) x 2 buc pana acestea raman stranse.

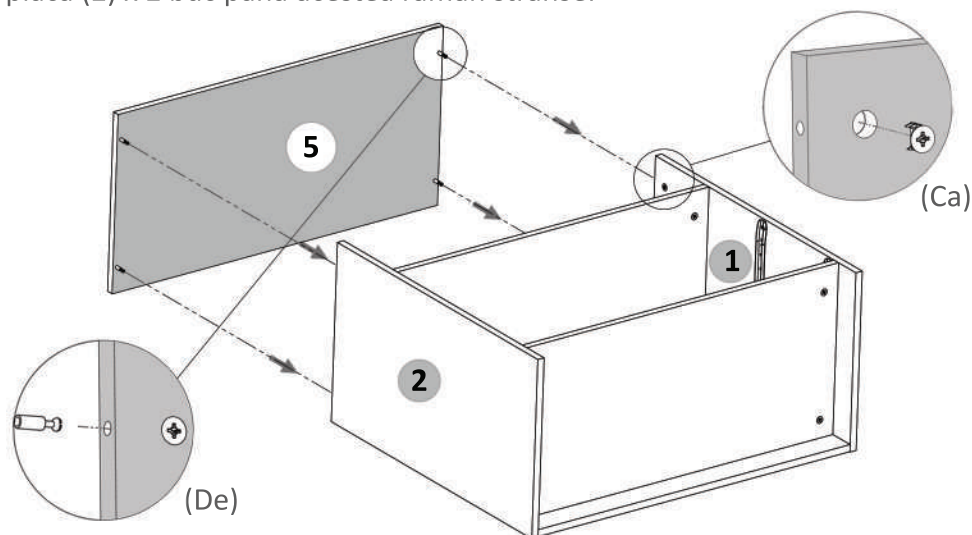

## Pasul 6 (Montaj HDF + Picioare)

Se masoara diagonalele sa fie in vinclu, dupa care se prind HDF-urile (7 si 8) folosindu-se de ciocan cu ajutorul unor cuie (Cu) x 32 buc, iar la imbinari se folosesc Profile H acolo unde este spatiu gol si saibe tip cupa (Sc) unde este polita.

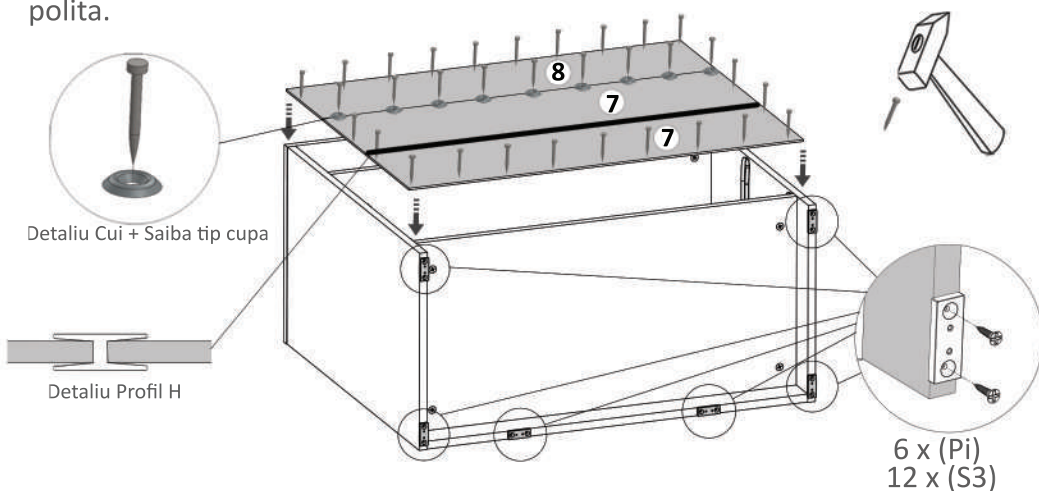

## Instrucțiuni montaj: Carcasa Comoda

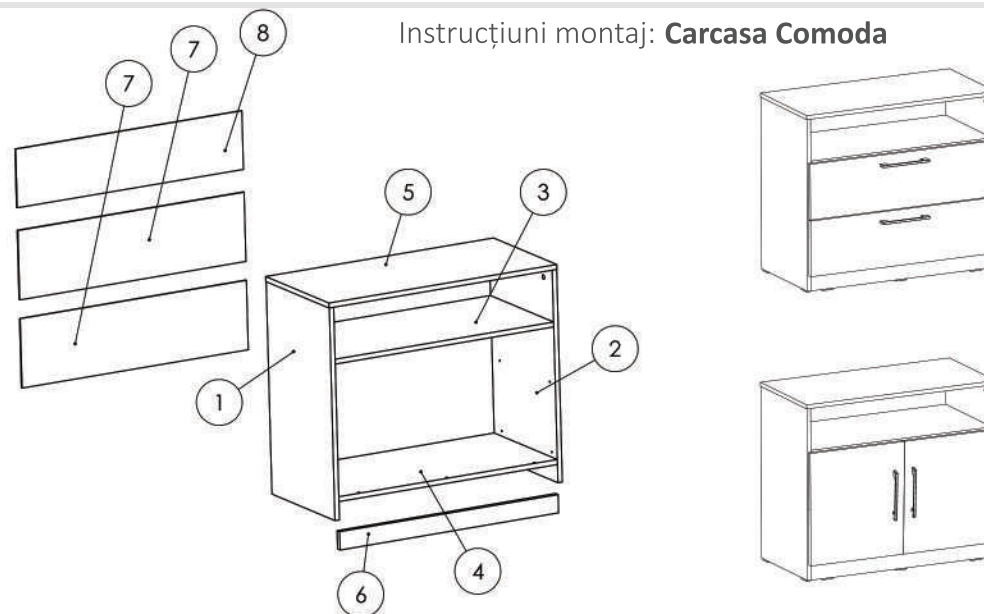

### Informatii Utile!

Aceasta carcasa este universala si se potriveste atat pentru modelul de comoda cu sertare cat si pentru modelul de comoda cu usi !

NR. REPER	COD REPER	DETALII	CANTITATE
1	LATERALA ST.	PAL 696 X 404 X 16	1
2	LATERALA DR.	PAL 696 X 404 X 16	1
3	POLITA FIXA	PAL 796 X 404 X 16	1
4	CAPAC INFERIOR	PAL 796 X 404 X 16	1
5	CAPAC SUPERIOR	PAL 830 X 404 X 16	1
6	SOCLU	PAL 796 X 60 X 16	1
7	HDF COMODA INFERIOR	HDF 824 X 227 X 4	2
8	HDF COMODA SUPERIOR	HDF 824 X 192 X 4	1

ATENȚIE: MONTAJUL NECORESPUNZĂTOR ATRAGE DUPĂ SINE PIERDEREA GARANȚIEI PRODUSULUI



Șurubelniță în cruce sau autofiletantă











Este **recomandat** ca montajul să fie făcut de **minim două persoane**



Un **ciocan** de dimensiune medie

## Elemente feronerie pentru 1 x Carcasa Comoda:

DEMONTABIL CU EXCENTRIC <b>De</b>  12	SURUB 3.5X16 <b>S3</b>  28	CAMA <b>Ca</b>  12	CONFIRMATOR 7X50 <b>Co</b>  3
CUIE <b>Cu</b>  32	BALAMALE APLICATE <b>Ba</b>  4	SAIBA TIP CUPA <b>Sc</b>  8	PICIOR PLASTIC 5 mm <b>Pi</b>  6

### Pasul 1 - Optional (Acest pas este valabil doar daca are sertare!)

Se prinde cu infiletanta (Gs) x 1 buc pe placa (1) si (Gd) x 1 buc pe placa (2), fiecare cu cate 2 suruburi (S3) in gaurile punctate din placa. (Detaliu 1)

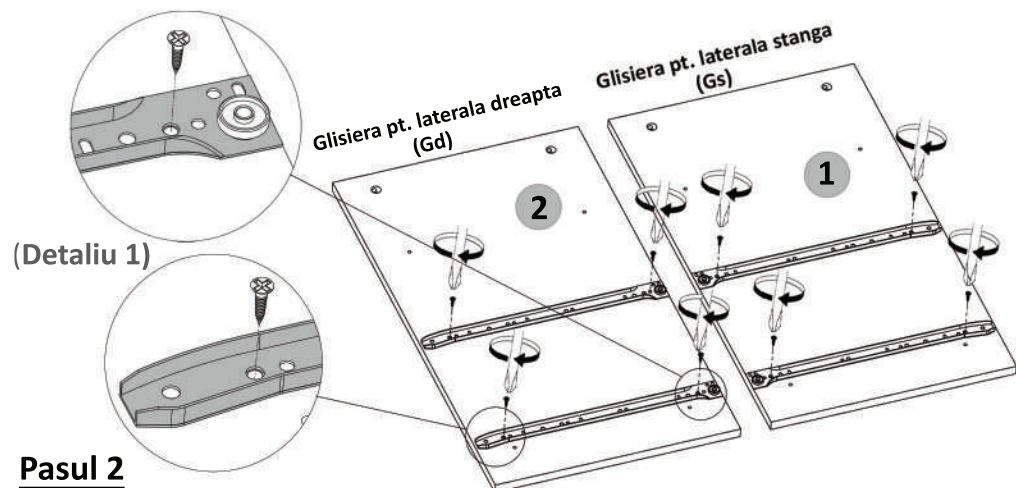

### Pasul 2

Se infileteaza cu surubelnita sau infiletanta electrica 4 x (De) pe placile (1) si (2) cate 2 / placa. (Detaliu 2)

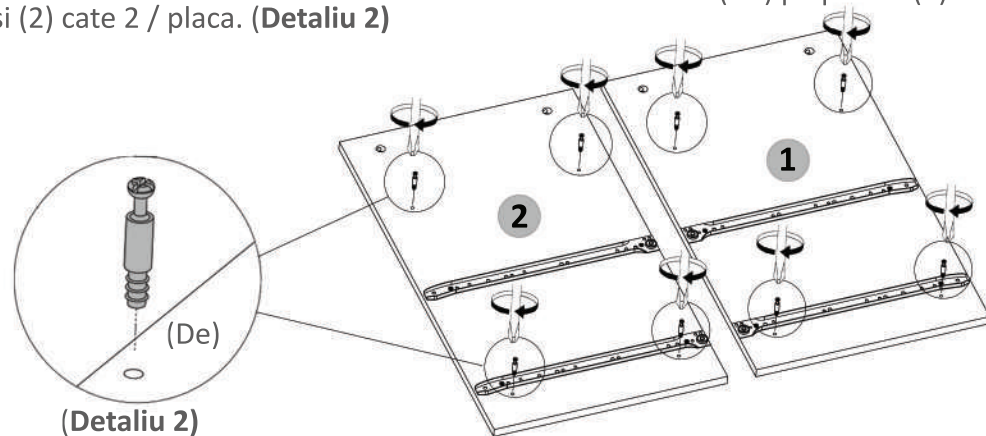

### Pasul 3 (Montaj Repere)

Se prinde placa (6) de placa (4) cu ajutorul celor 3 Confirmatoare (Co) in gaurile existente pe placa (4).

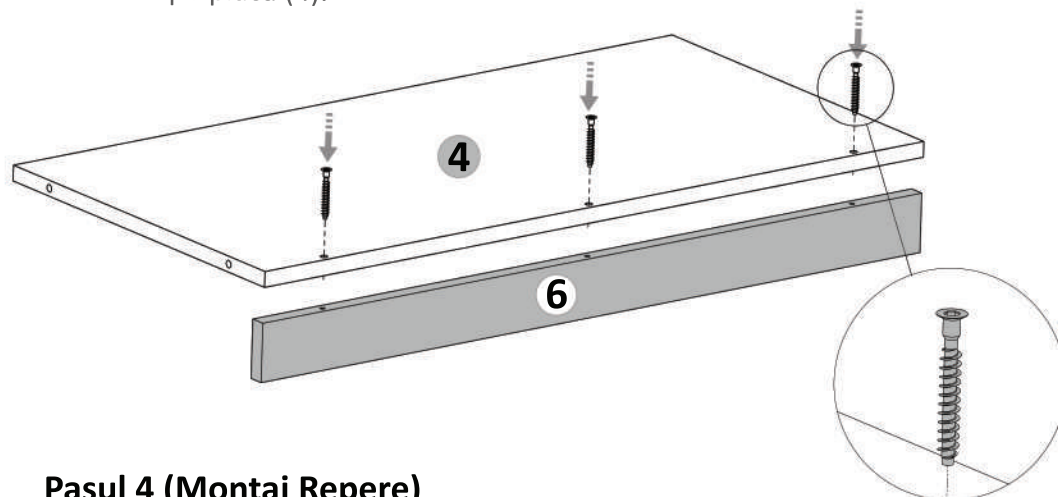

### Pasul 4 (Montaj Repere)

Se prind placile (1) si (2) de placile (3,4,6) cu demontabili (De) x 8 buc in gaurile prestabilite, urmand ca apoi sa se infileteze (Ca) x 8 buc pana acestea raman stranse.

