

## Tipuri de Montaj:

### Corp Pozitionat Orizontal Superior (Suspendat pe perete la inaltime)

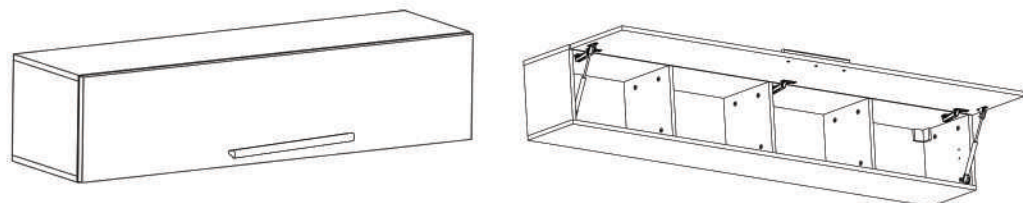

### Corp Pozitionat Orizontal Inferior (Suspendat pe perete sau pe podea)

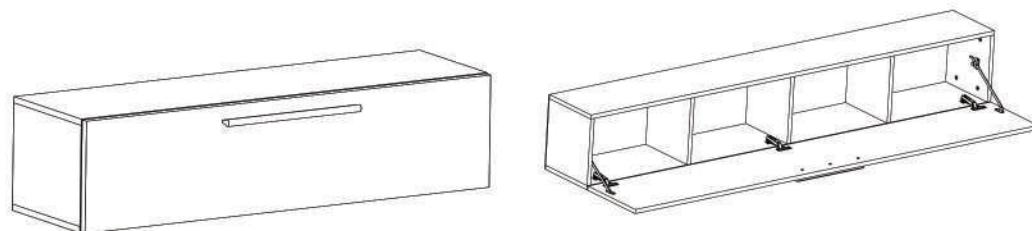

### Corp Pozitionat Vertical (Suspendat pe perete sau pe podea)

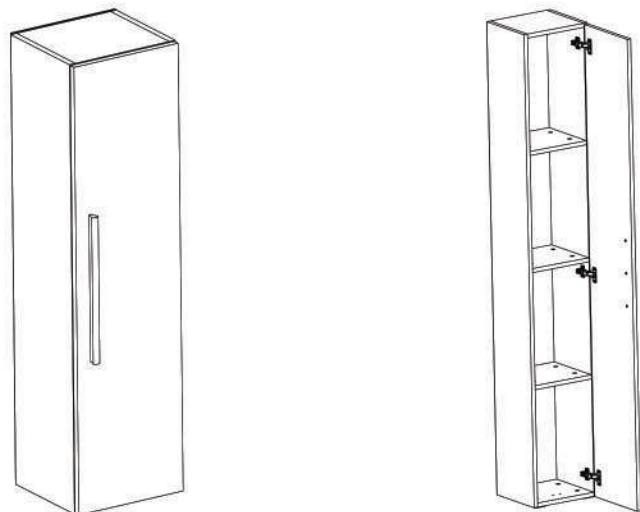

## Instrucțiuni montaj: Corp Living PATI 1850 - Pozitie Orizontala Superioara

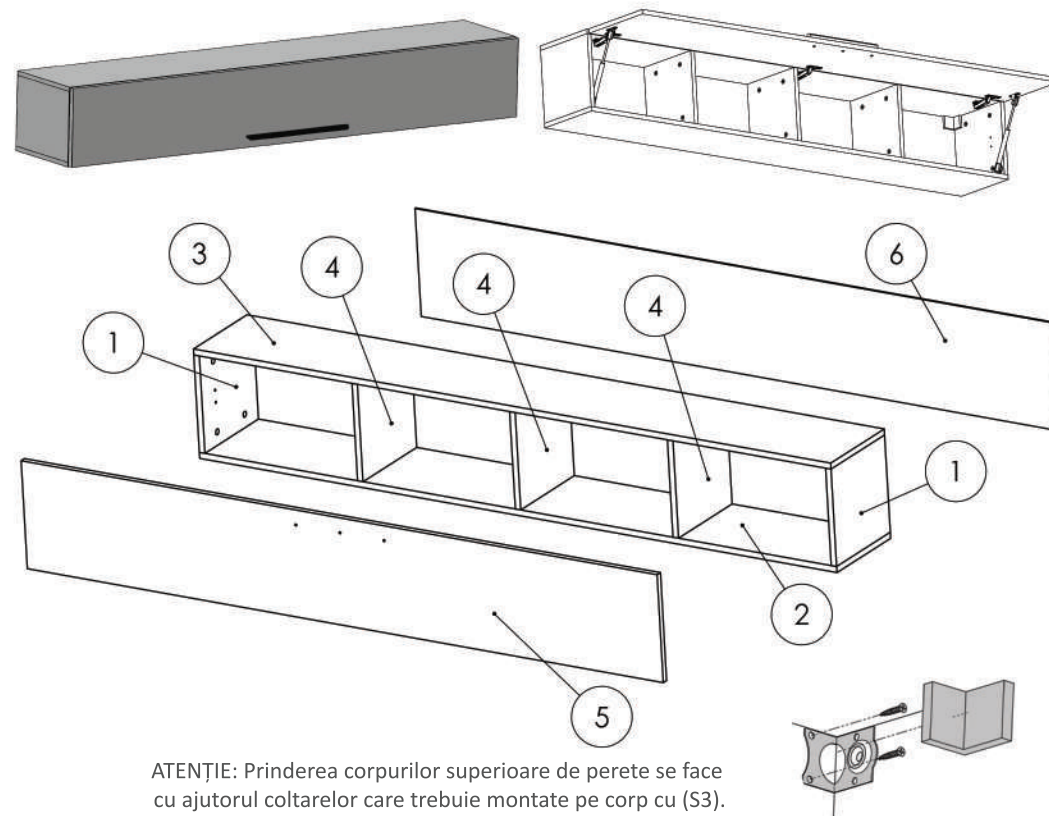

ATENȚIE: Prinderea corpurilor superioare de perete se face cu ajutorul coltarelor care trebuie montate pe corp cu (S3).

NR. REPER	DETALII	COD REPER	CANTITATE
1	PAL 258X250X16	TAVAN / FUND	2
2	PAL 1850X250X16	LATERALA DR.	1
3	PAL 1850X250X16	LATERALA ST.	1
4	PAL 258X250X16	INTERMEDIARA	3
5	PAL 1376X286X16	USA	1
6	HDF 1376X286X4	HDF	1

ATENȚIE: MONTAJUL NECORESPUNZĂTOR ATRAGE DUPĂ SINE PIERDEREA GARANȚIEI PRODUSULUI



Șurubelniță în cruce sau autofiletantă













Este **recomandat** ca montajul să fie făcut de **minim două persoane**



Un **ciocan** de dimensiune medie

## Elemente feronerie pt. corp pozitionat orizontal superior:

DEMONTABIL CU EXCENTRIC <b>De</b>  20	Coltar Plastic Alb <b>Cp</b>  3	SURUB TIP CONFIRMATOR 4x27 <b>S4</b>  3	CAMA <b>Ca</b>  20
CUIE <b>Cu</b>  46	TALPA LATERALA PISTON <b>TL</b>  2	BALAMALE APLICATE <b>Ba</b>  3	SURUB 3.5X16 <b>S3</b>  28
PISTON <b>Ps</b>  2	TALPA USA PISTON <b>TU</b>  2	MANER FULYA 300 <b>Mn</b>  1	

### Pasul 1 (Montaj Demontabili)

Se prinde cu infiletanta sau surubelnita 20 x (De) pe placile laterale (2) si (3).

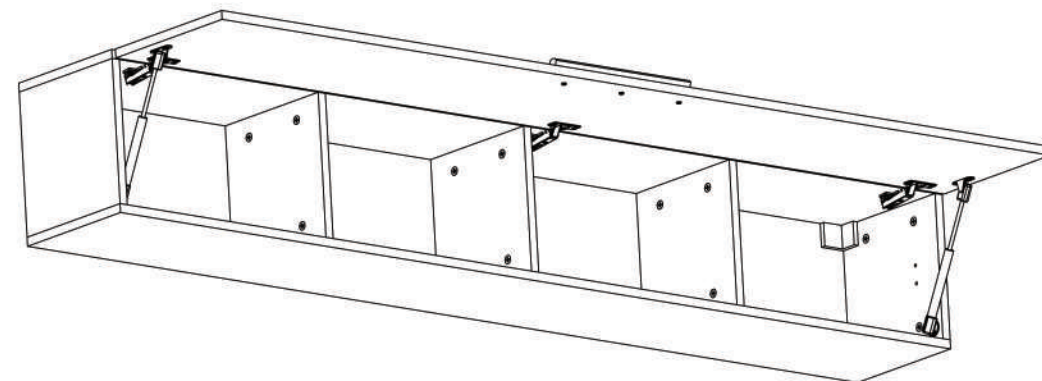
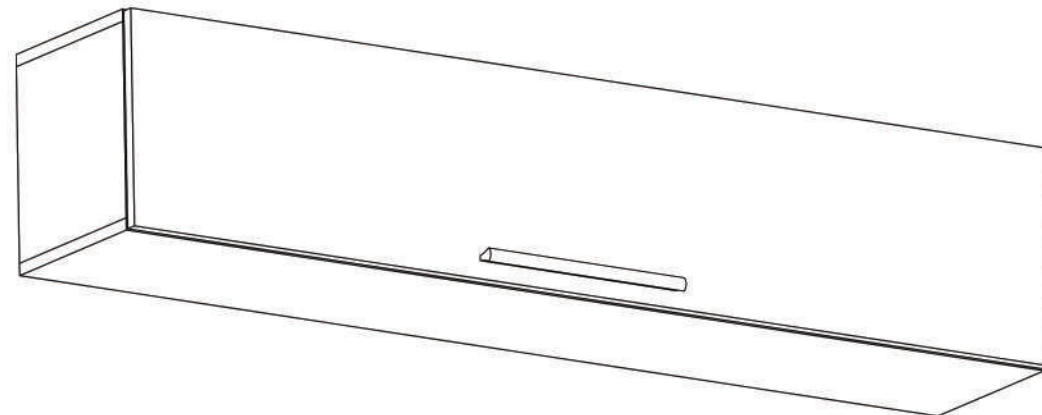
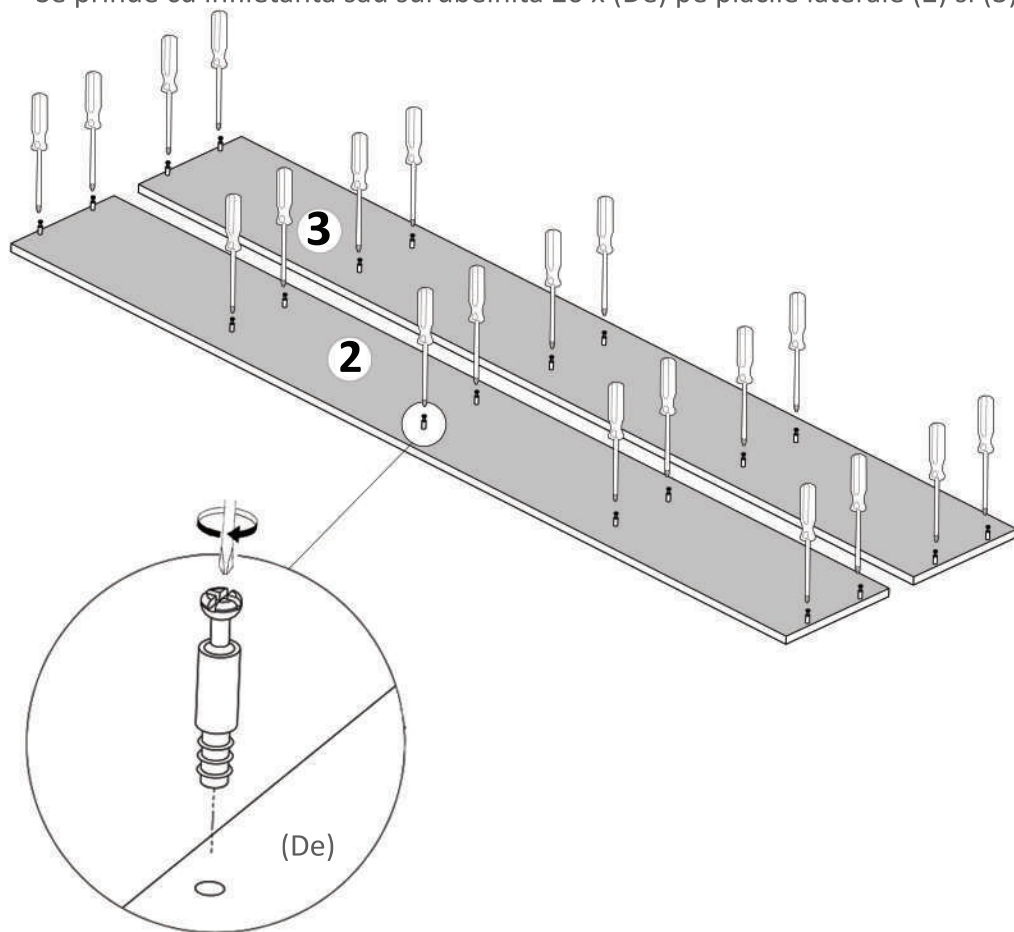

## Pasul 13 (Montaj Maner)

Se monteaza pe placa (5) maner (Mn) x 1 buc cu suruburi (S4) M4x27 - 3 buc in gaurile existente pe placa.

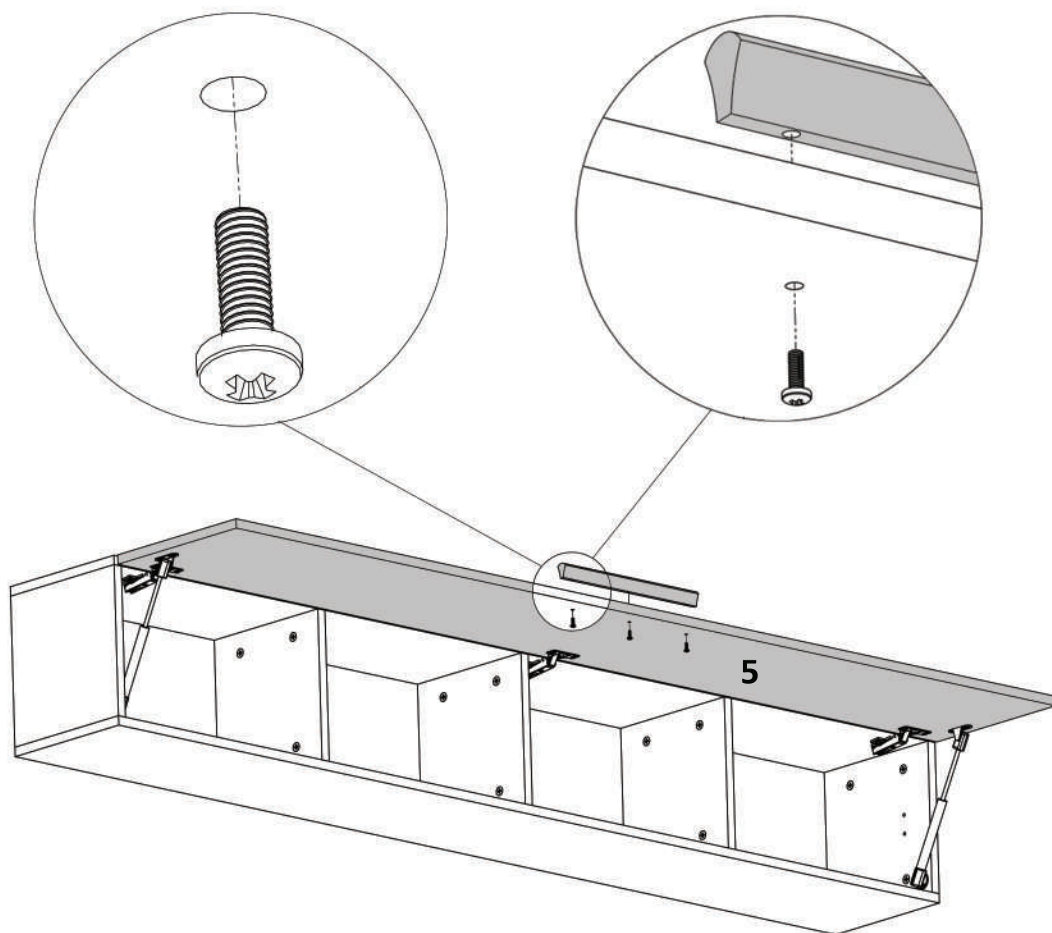

## Pasul 2 (Semne pt. talpa laterala piston)

Se pozitioneaza sablonul de hartie cu inscriptia (**Sablon Aplicare Piston Gaz Usa - Se Foloseste la Aplicarea pe Laterala Stanga**) pe una din placile (1) si se perforoaza cele trei gauri cu un creion ca si in imaginea de mai jos rezultand astfel semnele necesare pentru montajul piesei (TL). (**detaliu 2**)

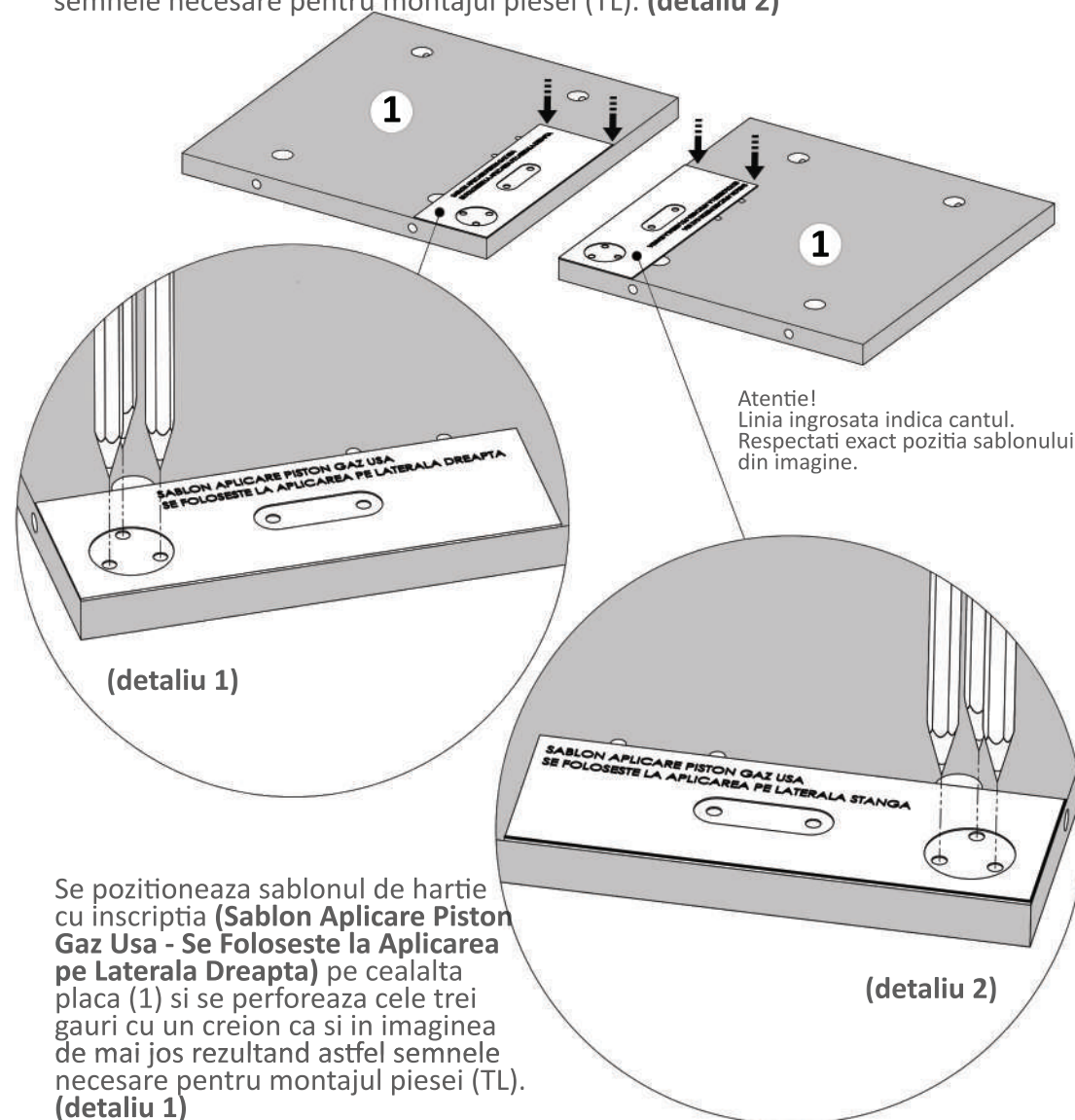

Se pozitioneaza sablonul de hartie cu inscriptia (**Sablon Aplicare Piston Gaz Usa - Se Foloseste la Aplicarea pe Laterala Dreapta**) pe cealalta placa (1) si se perforoaza cele trei gauri cu un creion ca si in imaginea de mai jos rezultand astfel semnele necesare pentru montajul piesei (TL). (**detaliu 1**)

### Pasul 3 (Montaj talpa laterala piston)

Se pozitioneaza (TL) x 2 buc pe placile (1) in locurile pe care le-ati insemnat inainte cu creionul si se prind cu suruburi (S3) 3.5x16 -3buc.

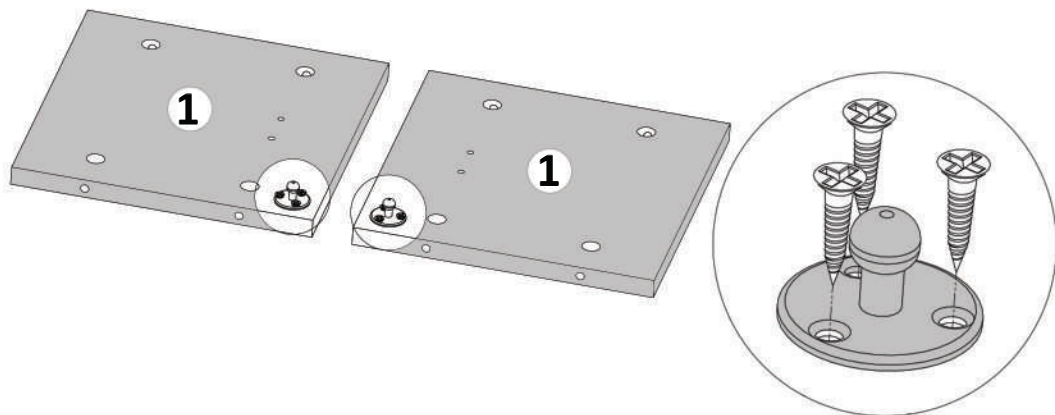

### Pasul 4 (Montaj repere)

Se prind de placa laterala (3) placile (1) si (4) cu demontabili (De) x 10 buc - cate 2buc / placa in gaurile prestabilite, urmand ca apoi sa se infileteze (Ca)x 10 buc pana raman stranse.

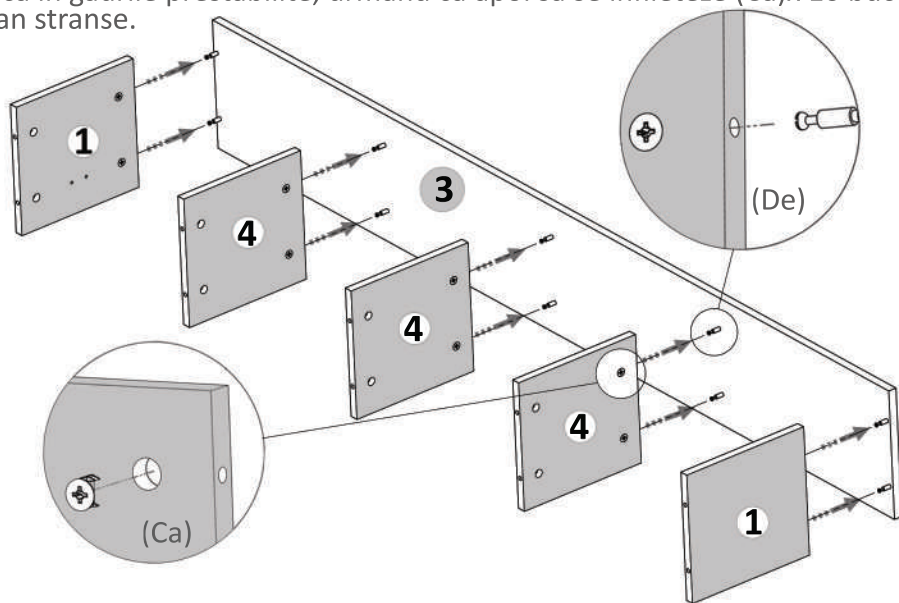

### Pasul 12 (Montaj coltare)

Se monteaza pe placile (1) Coltare (Cp) x 3 buc cu suruburi (S3) 3.5x16 - 6 buc cate 2 suruburi / coltar. Aceste coltare o sa va ajute sa prindeti corpurile de perete.

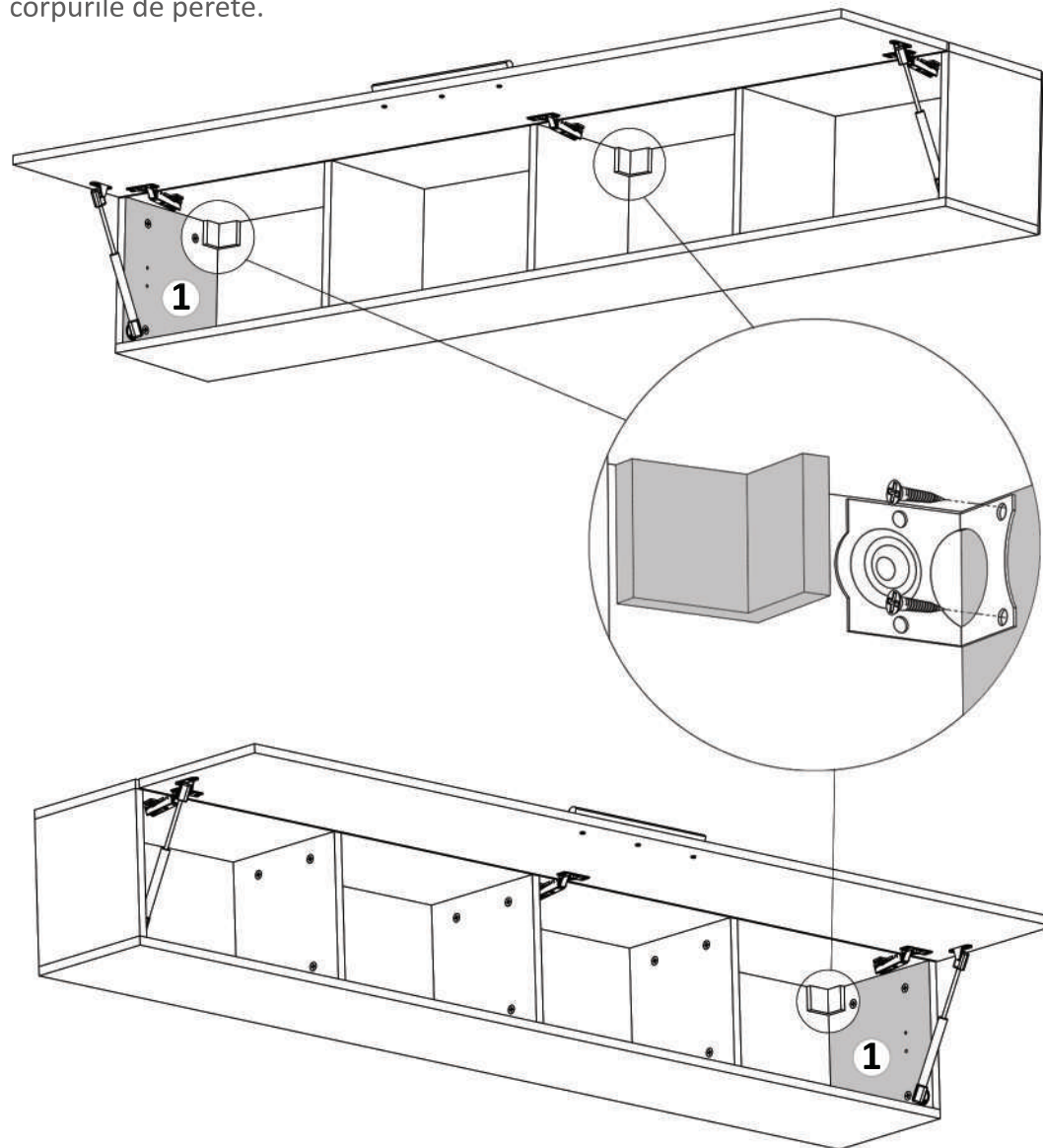

### Pasul 10 (Montaj Talpa Usa Piston)

Se pozitioneaza (TU) x 2 buc pe placa (5) in locurile pe care le-ati insemnat inainte cu creionul si se prinde cu suruburi (S3) 3.5x16 -4buc cate 2 suruburi / piesa.

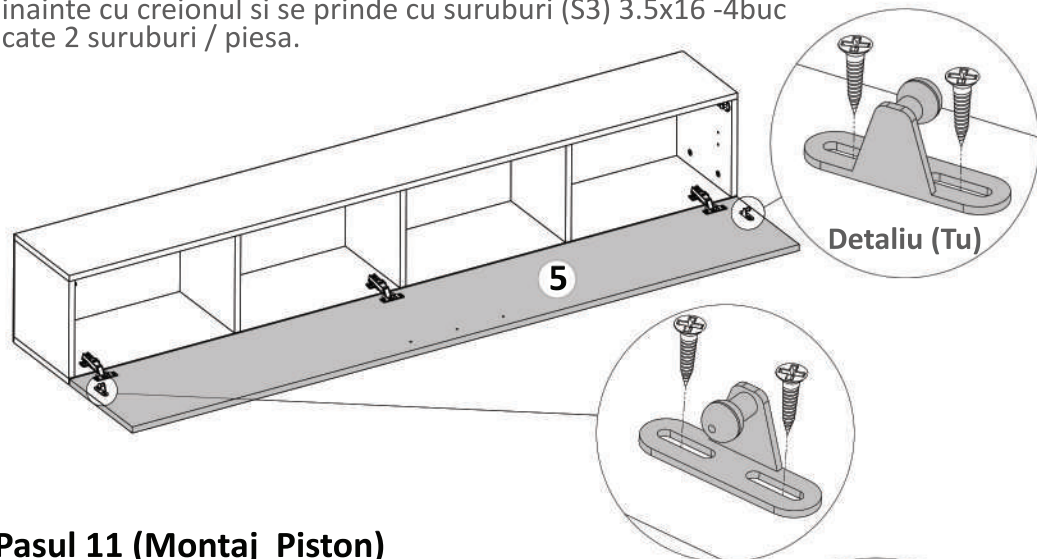

### Pasul 11 (Montaj Piston)

Se monteaza (Ps) x 2 buc introducand pistonul in (TU) si (TL) atat in partea dreapta cat si in partea stanga.

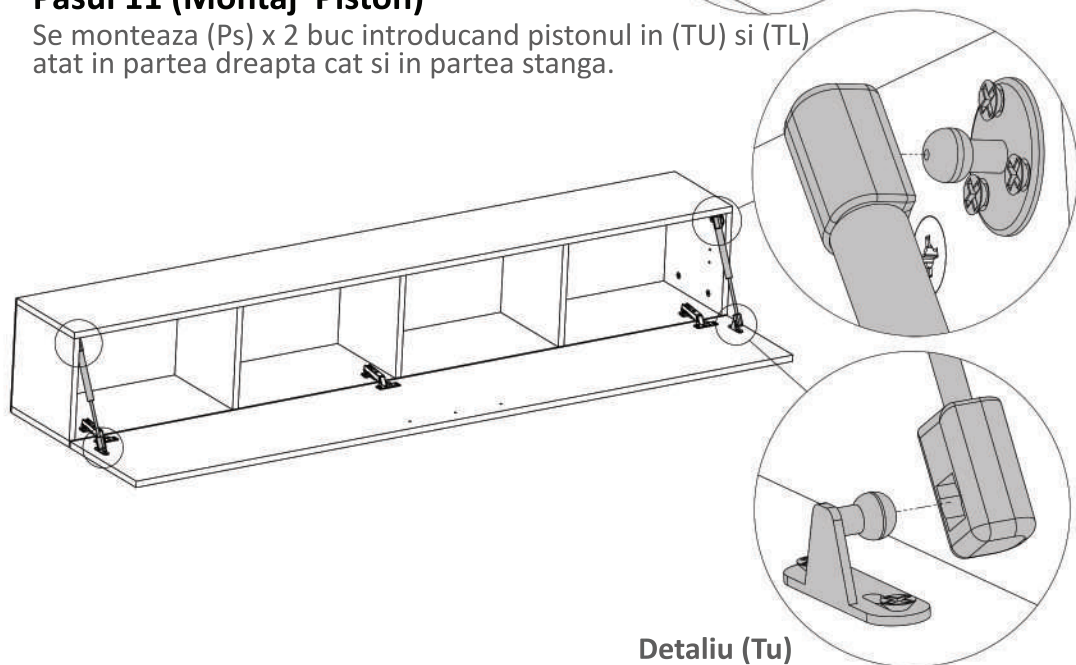

Detaliu (Tu)

### Pasul 5 (Montaj repere)

Se prinde placa laterala (2) de placile (1) si (4) cu demontabili (De) x 10 buc in gaurile prestabilite, urmand ca apoi sa se infiletzeze (Ca) x 10 buc pana raman stranse.

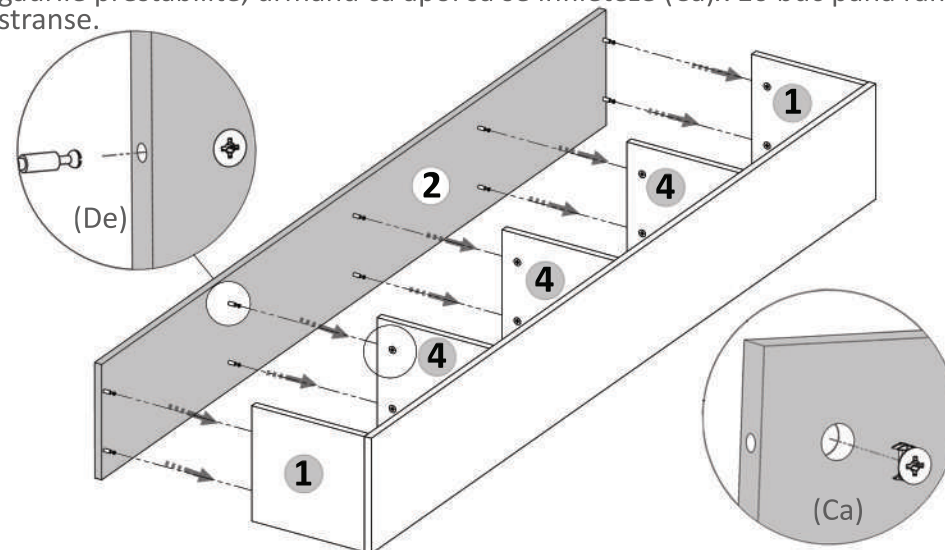

### Pasul 6 (Montaj HDF)

Se masoara diagonalele sa fie in vinclu, dupa care se prinde HDF-ul (6) folosindu-se de ciocan cu ajutorul unor cuie (Cu) x 46 buc.



Se masoara diagonalele sa fie in vinclu inainte de a monta HDF-ul!

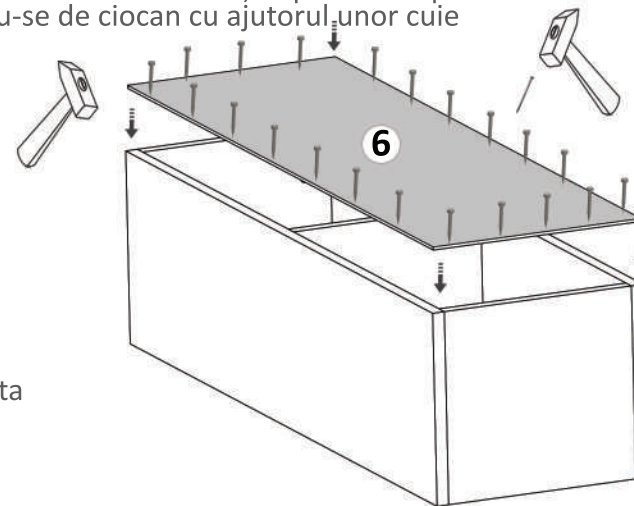

## Pasul 7 (Montaj Balamale pe Usa)

Se prinde pe placa (5) balamale (Ba) x 3buc cu suruburi (S3) x 6 buc, cate 2 buc / balama.

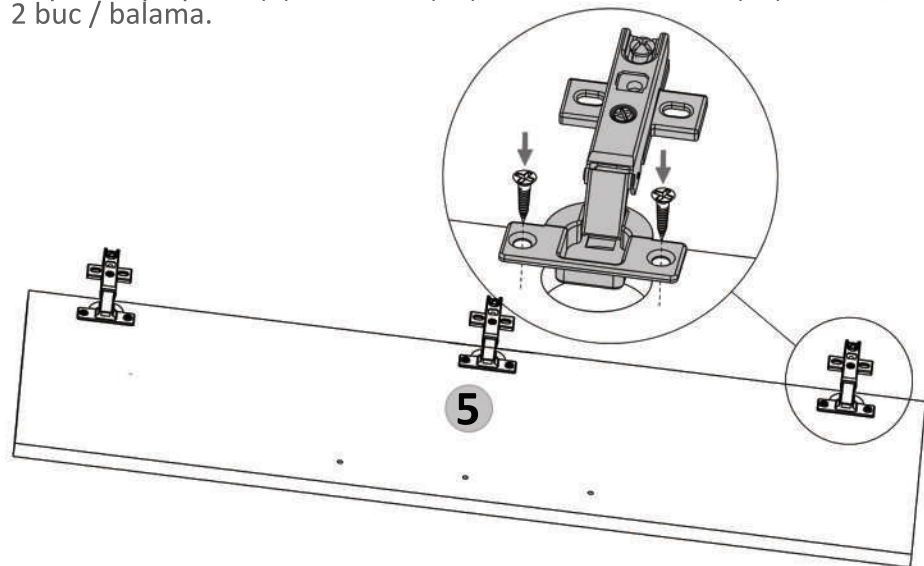

## Pasul 8 (Montaj Balamale)

Se lipeste placa (5) de cantul placii (2) si se monteaza pe placa (2) balamale (Ba) x 3 buc folosindu-se suruburi 3.5x16 (S3) - cate 2 / balama.

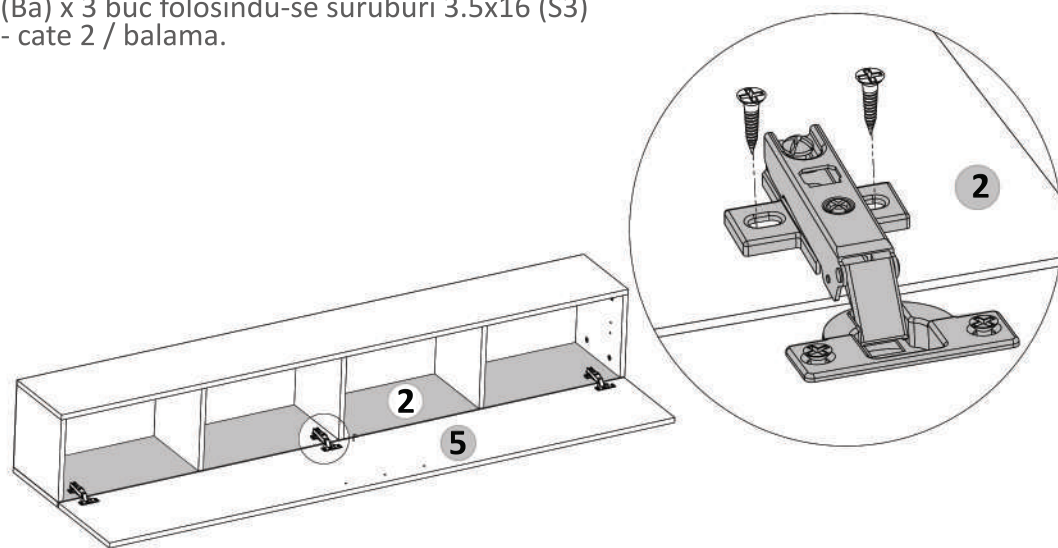

## Pasul 9 (Semne pt. talpa usa piston)

Se pozitioneaza sablonul de hartie cu inscriptia (**Sablon Aplicare Piston Gaz Usa - Se Foloseste la Aplicarea pe Laterala Dreapta**) pe placa (5) si se perforoaza cele doua gauri cu un creion ca si in imaginea de mai jos rezultand astfel semnele necesare pentru montajul piesei (TU). (**detaliu 2**)

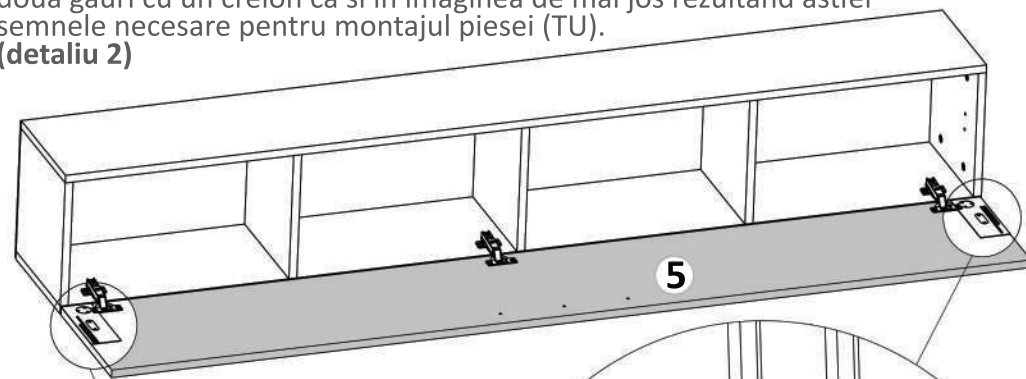

Atentie!  
Linia ingrosata indica  
cantul. Respectati exact  
pozitia sablonului din  
imagine.

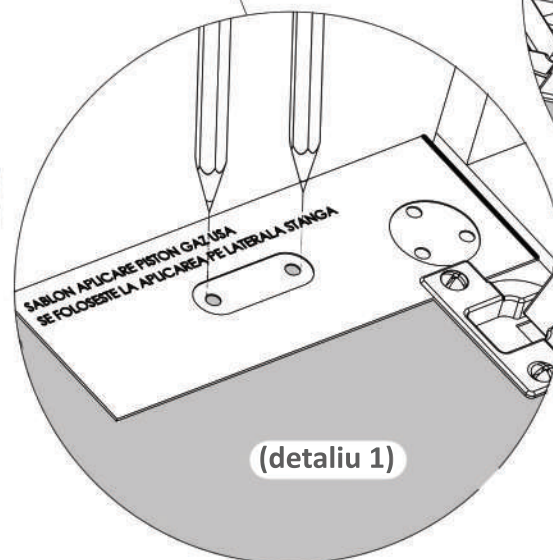

(detaliu 1)

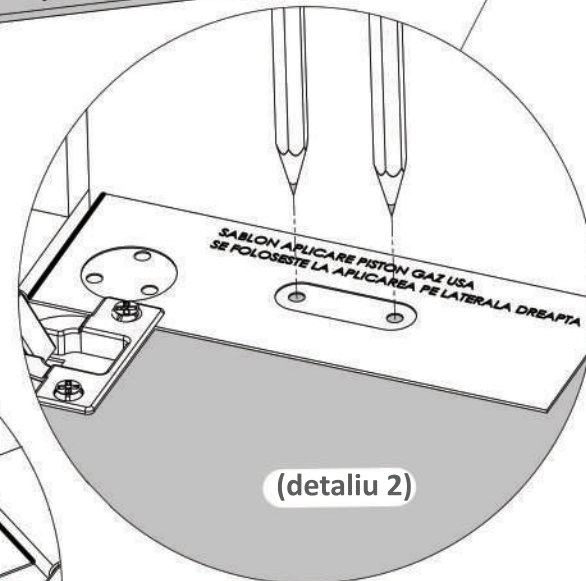

(detaliu 2)

Se pozitioneaza sablonul de hartie cu inscriptia (**Sablon Aplicare Piston Gaz Usa - Se Foloseste la Aplicarea pe Laterala Stanga**) pe placa (5) si se perforoaza cele doua gauri cu un creion ca si in imaginea de mai jos rezultand astfel semnele necesare pentru montajul piesei (TU). (**detaliu 1**)