

Tipuri de Montaj:

Corp Pozitionat Orizontal Superior (Suspendat pe perete la inaltime)

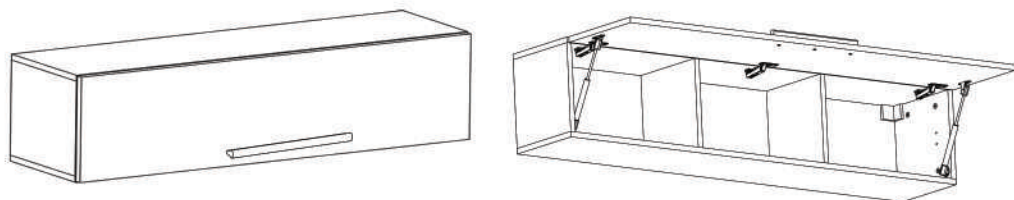

Corp Pozitionat Orizontal Inferior (Suspendat pe perete sau pe podea)

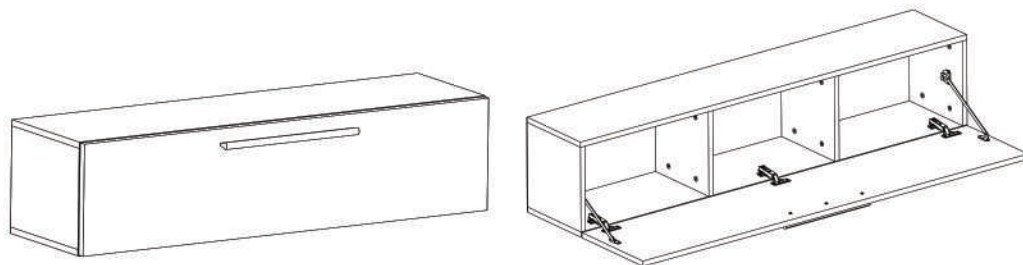

Corp Pozitionat Vertical (Suspendat pe perete sau pe podea)

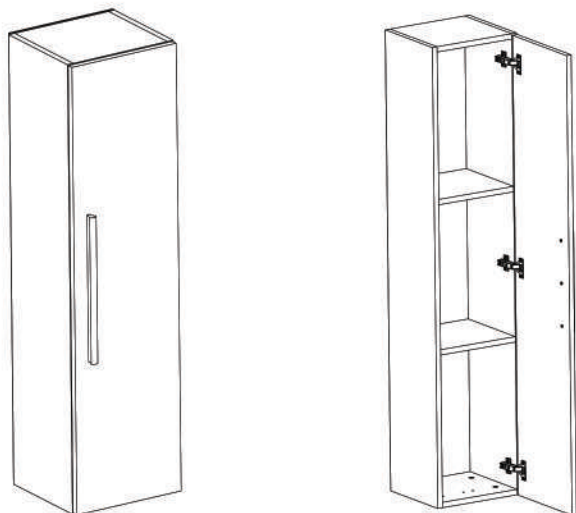

Instrucțiuni montaj: Corp Living 1380 - Pozitie Orizontala Superioara

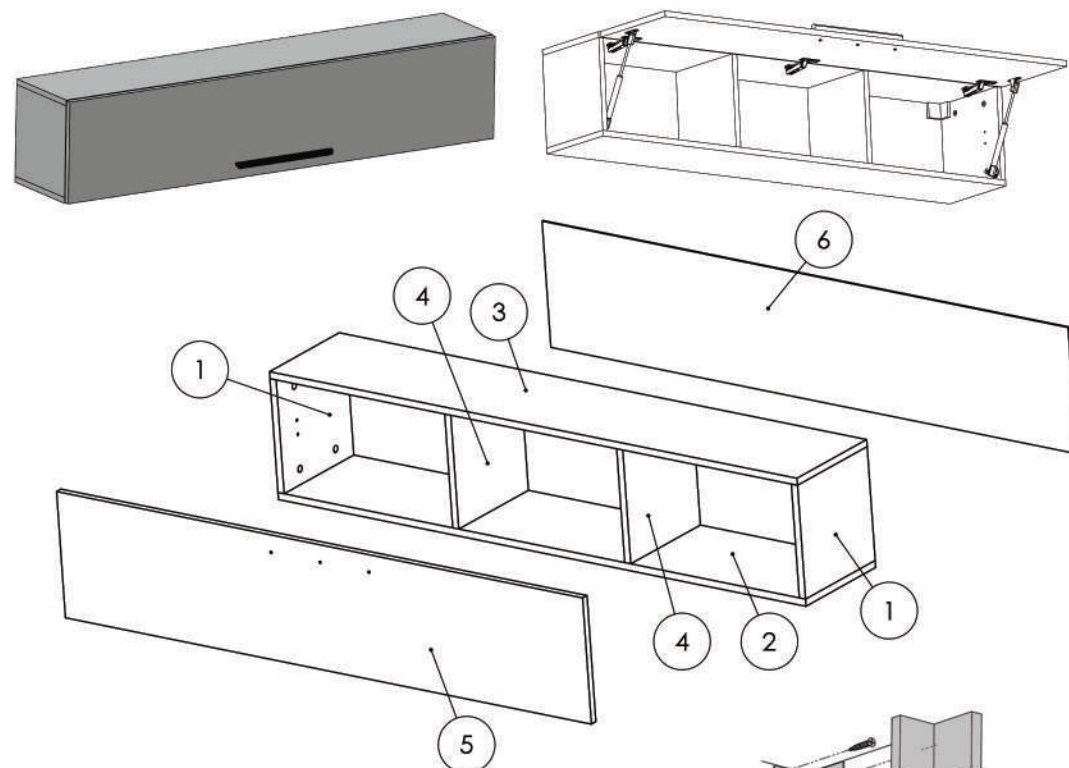

ATENȚIE: Prinderea corpurilor superioare de perete se face cu ajutorul colțarelor care trebuie montate pe corp cu (S3).

NR. REPER	DETALII	COD REPER	CANTITATE
1	PAL 258X250X16	FUND / TAVAN	2
2	PAL 1380X250X16	LATERALA DREAPTA	1
3	PAL 1380X250X16	LATERALA STANGA	1
4	PAL 258X250X16	INTERMEDIARA	2
5	PAL 1376X286X16	USA	1
6	HDF 1376X286X4	HDF	1

ATENȚIE: MONTAJUL NECORESPUNZĂTOR ATRAGE DUPĂ SINE PIERDEREA GARANȚIEI PRODUSULUI



Șurubelniță în cruce sau autofiletantă













Este **recomandat** ca montajul să fie făcut de **minim două persoane**



Un **ciocan** de dimensiune medie

Elemente feronerie pt. corp pozitionat orizontal superior:

DEMONTABIL CU EXCENTRIC De  16	Coltar Plastic Alb Cp  2	SURUB TIP CONFIRMATOR 4x27 S4  3	CAMA Ca  16
CUIE Cu  30	TALPA LATERALA PISTON TL  2	BALAMALE APLICATE Ba  3	SURUB 3.5X16 S3  26
PISTON Ps  2	TALPA USA PISTON TU  2	MANER FULYA 300 Mn  1	

Pasul 1 (Montaj Demontabili)

Se prinde cu infiletanta sau surubelnita 16 x (De) pe placile laterale (2) si (3).

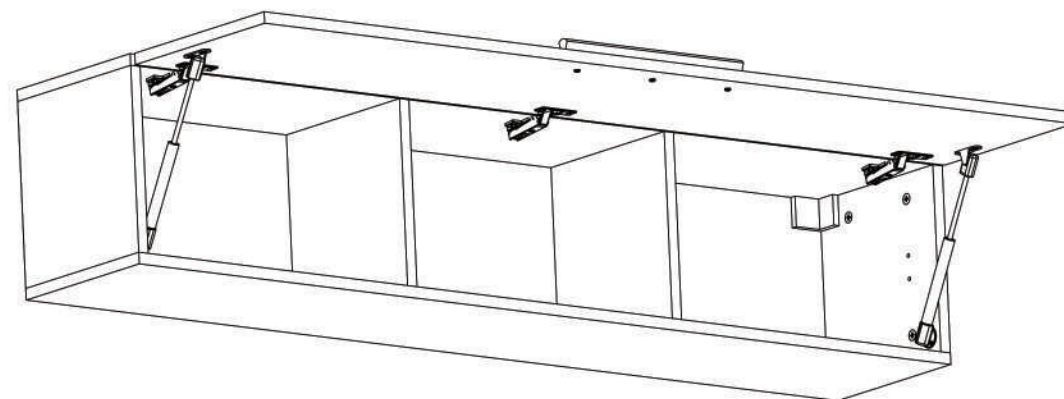
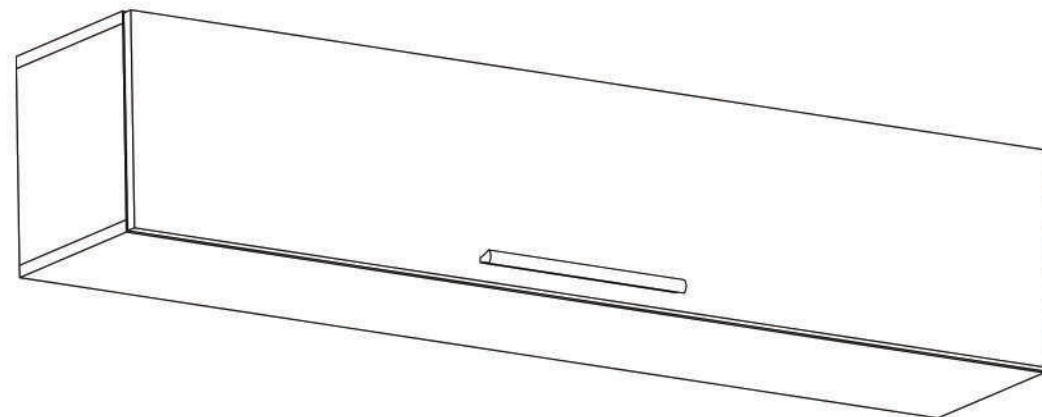
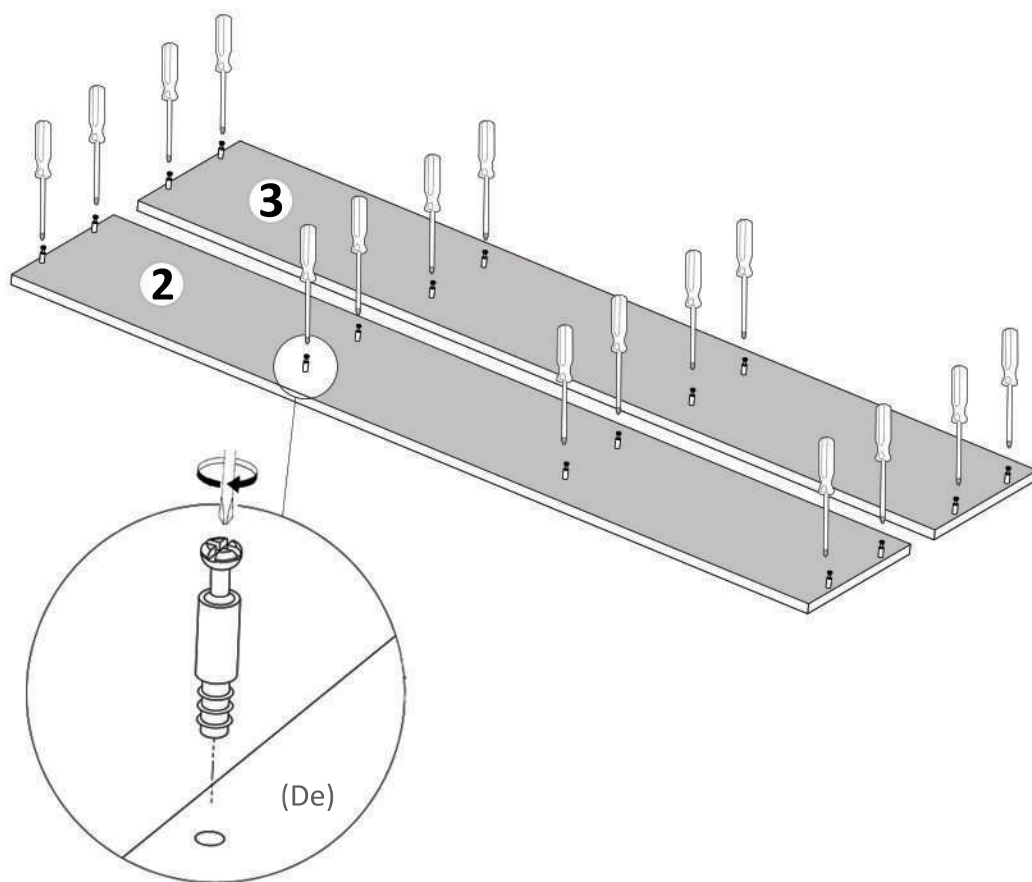

Pasul 13 (Montaj Maner)

Se monteaza pe placa (5) maner (Mn) x 1 buc cu suruburi (S4) M4x27 - 3 buc in gaurile existente pe placa.

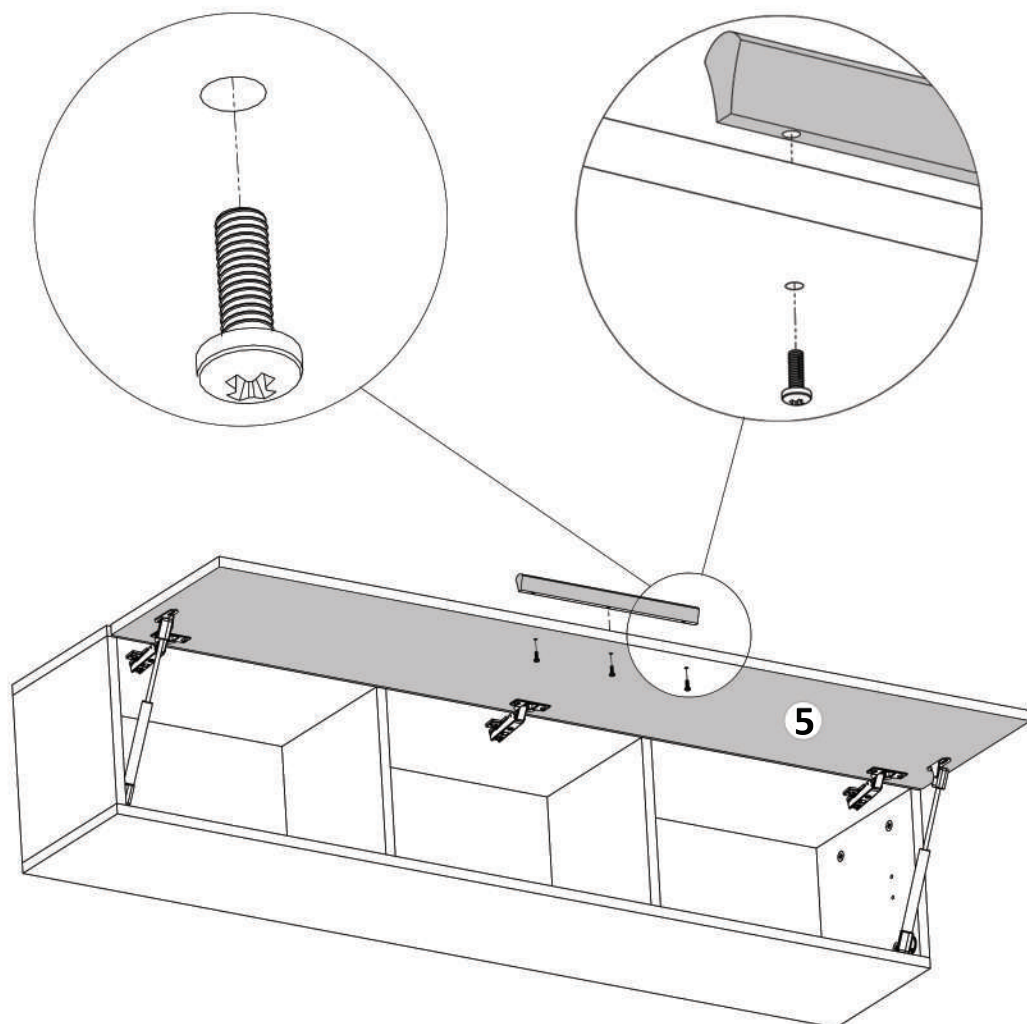

Pasul 2 (Semne pt. talpa laterala piston)

Se pozitioneaza sablonul de hartie cu inscriptia (**Sablon Aplicare Piston Gaz Usa - Se Foloseste la Aplicarea pe Lateral Stanga**) pe una din placile (1) si se perforoaza cele trei gauri cu un creion ca si in imaginea de mai jos rezultand astfel semnele necesare pentru montajul piesei (TL). (**detaliu 2**)

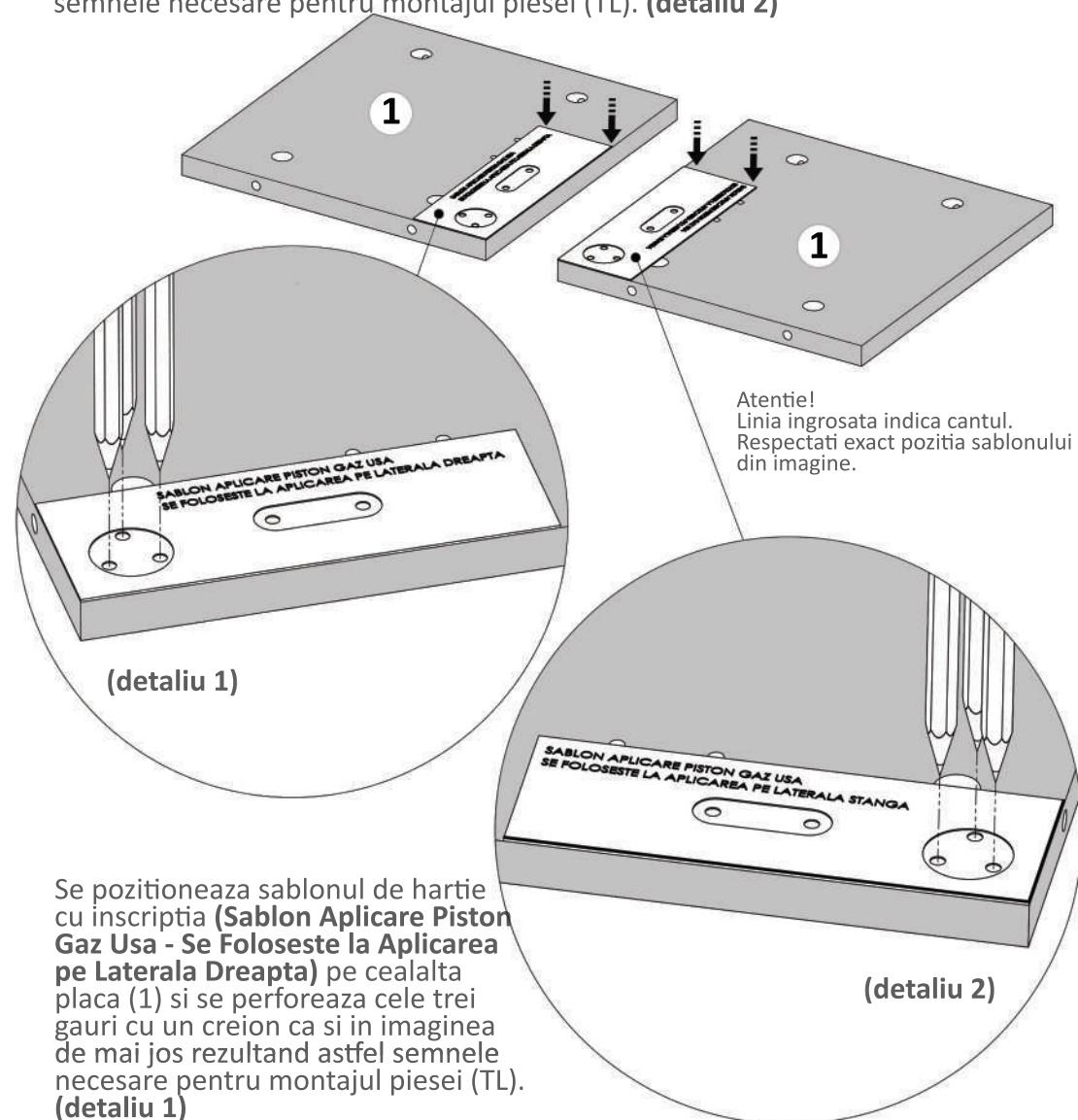

Se pozitioneaza sablonul de hartie cu inscriptia (**Sablon Aplicare Piston Gaz Usa - Se Foloseste la Aplicarea pe Lateral Dreapta**) pe cealalta placa (1) si se perforoaza cele trei gauri cu un creion ca si in imaginea de mai jos rezultand astfel semnele necesare pentru montajul piesei (TL). (**detaliu 1**)

Pasul 3 (Montaj talpa laterala piston)

Se pozitioneaza (TL) x 2 buc pe placile (1) in locurile pe care le-ati insemnat inainte cu creionul si se prind cu suruburi (S3) 3.5x16 -3buc.

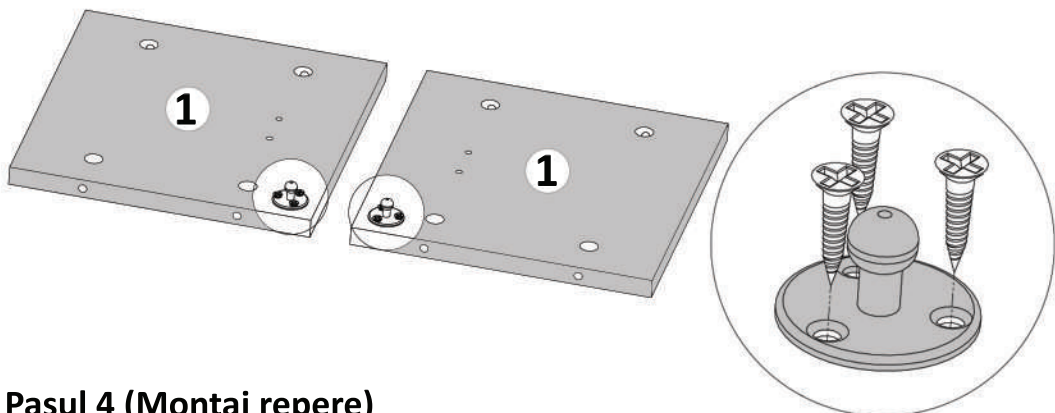

Pasul 4 (Montaj repere)

Se prind de placa laterala (3) placile (1) si (4) cu demontabili (De) x 8 buc - cate 2buc / placa in gaurile prestabilite, urmand ca apoi sa se infiletze (Ca)x 8 buc pana raman stranse.

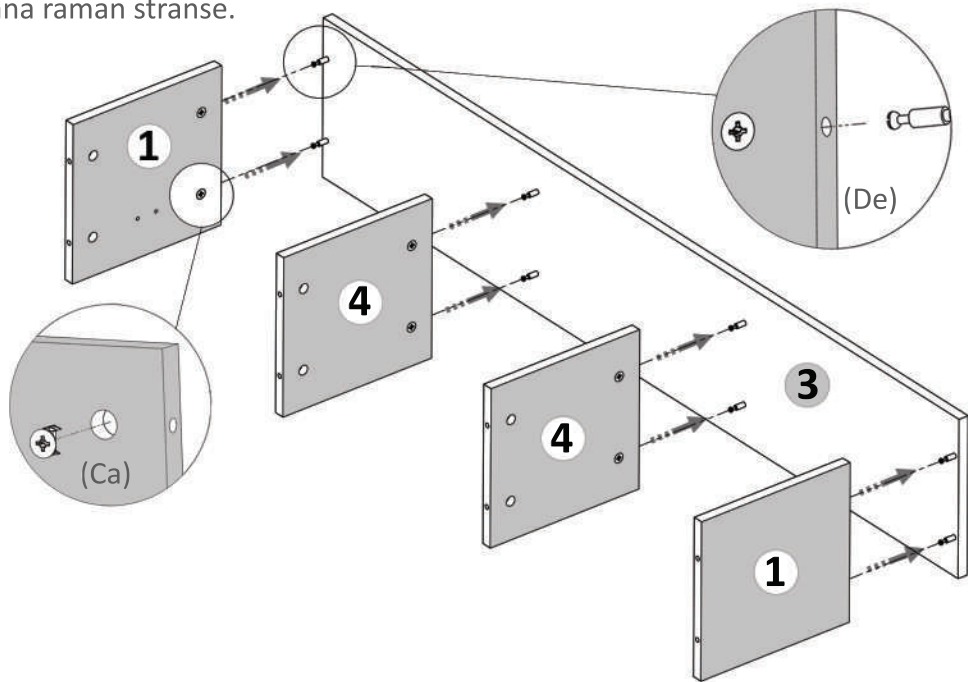

Pasul 12 (Montaj coltare)

Se monteaza pe placile (1) Coltare (Cp) x 2 buc cu suruburi (S3) 3.5x16 - 4 buc cate 2 suruburi / coltar. Aceste coltare o sa va ajute sa prindeti corpurile de perete.

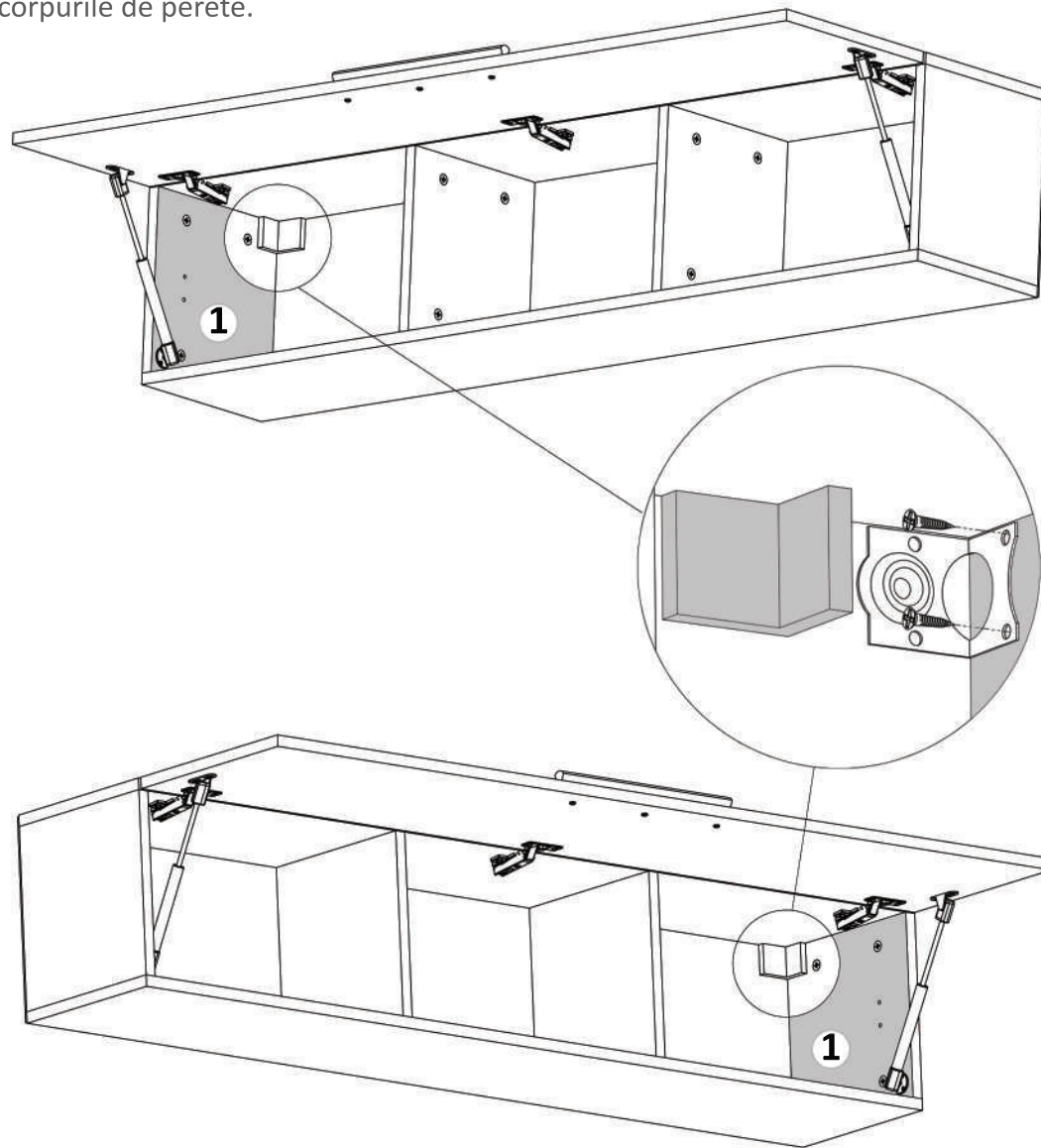

Pasul 10 (Montaj Talpa Usa Piston)

Se pozitioneaza (TU) x 2 buc pe placa (5) in locurile pe care le-ati insemnat inainte cu creionul si se prinde cu suruburi (S3) 3.5x16 -4buc cate 2 suruburi / piesa.

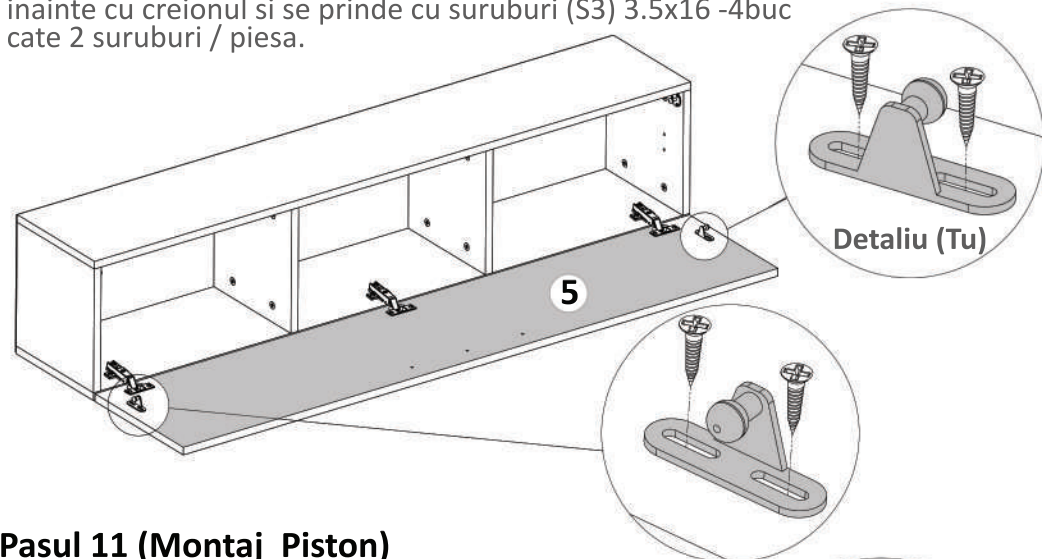

Pasul 11 (Montaj Piston)

Se monteaza (Ps) x 2 buc introducand pistonul in (TU) si (TL) atat in partea dreapta cat si in partea stanga.

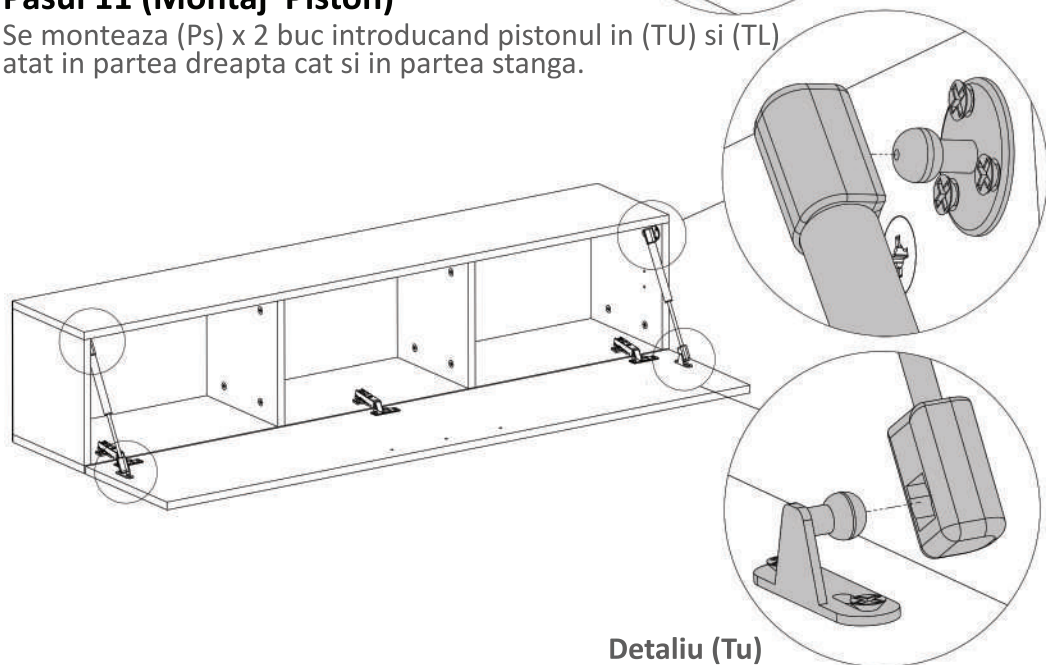

Detaliu (Tu)

Pasul 5 (Montaj repere)

Se prinde placa laterala (2) de placile (1) si (4) cu demontabili (De) x 8 buc in gaurile prestabilite, urmand ca apoi sa se infileteze (Ca) x 8 buc pana raman stranse.

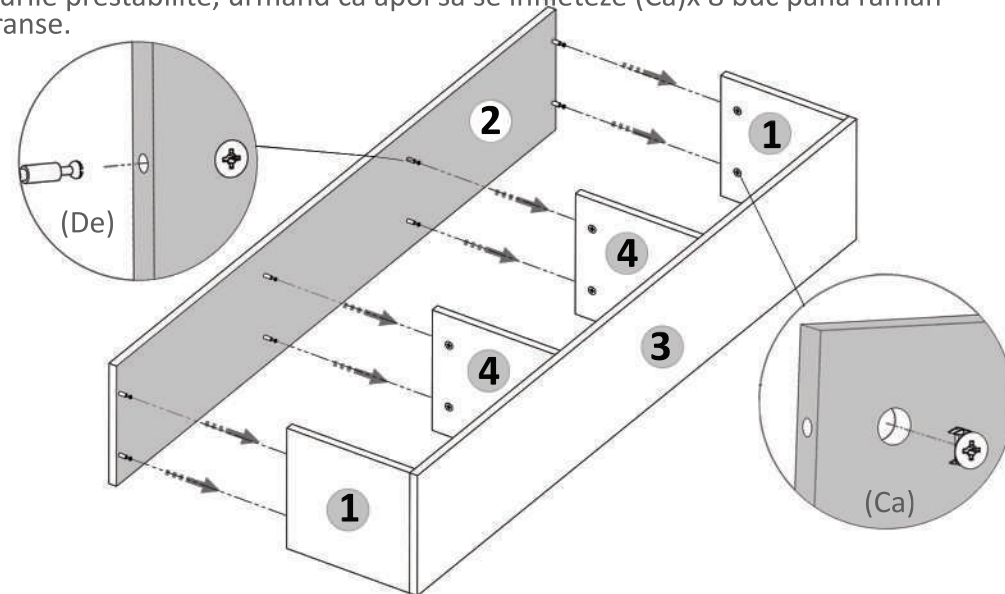

Pasul 6 (Montaj HDF)

Se masoara diagonalele sa fie in vinclu, dupa care se prinde HDF-ul (6) folosindu-se de ciocan cu ajutorul unor cuie (Cu) x 30 buc.

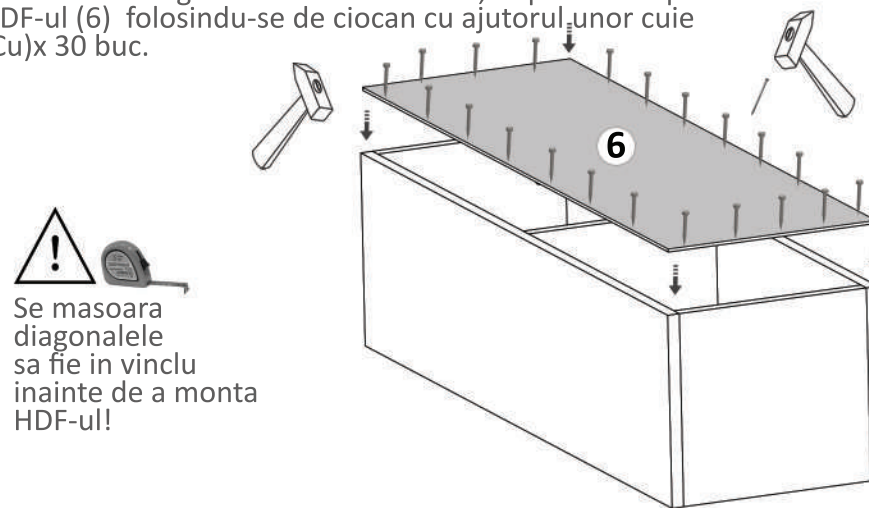

Se masoara diagonalele sa fie in vinclu inainte de a monta HDF-ul!

Pasul 7 (Montaj Balamale pe Usa)

Se prinde pe placa (5) balamale (Ba) x 3buc cu suruburi (S3) x 6 buc, cate 2 buc / balama.

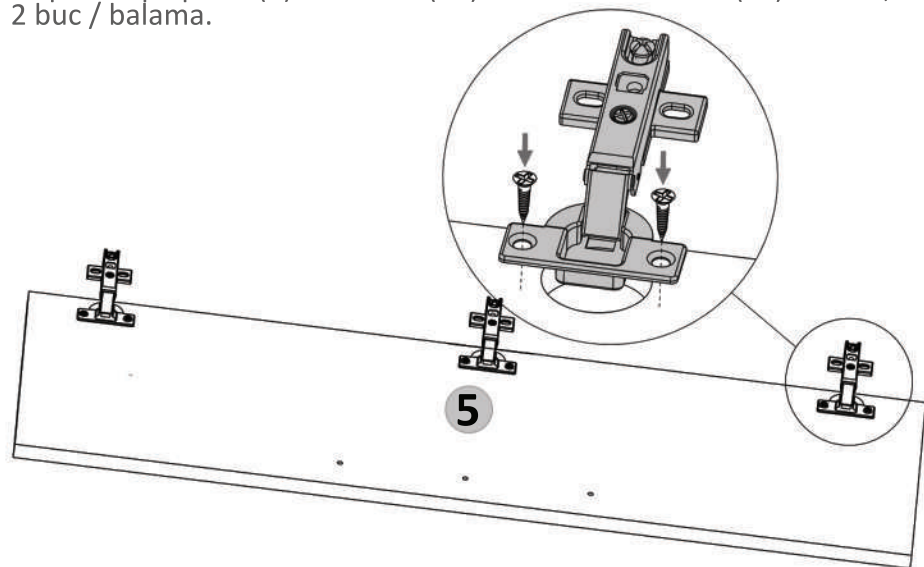

Pasul 8 (Montaj Balamale)

Se lipeste placa (5) de cantul placii (2) si se monteaza pe placa (2) balamale (Ba) x 3 buc folosindu-se suruburi 3.5x16 (S3) - cate 2 / balama.

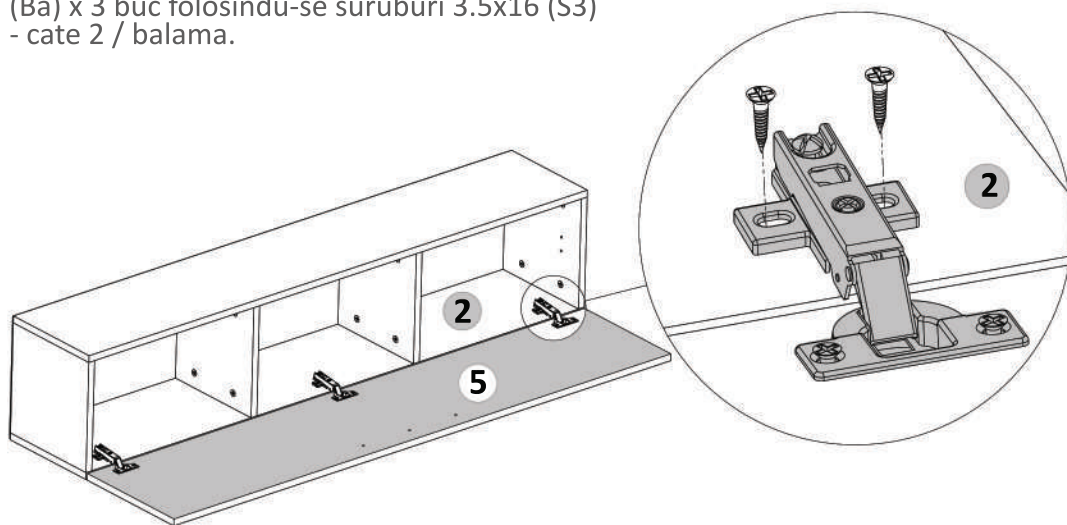

Pasul 9 (Semne pt. talpa usa piston)

Se pozitioneaza sablonul de hartie cu inscriptia (**Sablon Aplicare Piston Gaz Usa - Se Foloseste la Aplicarea pe Laterala Dreapta**) pe placa (5) si se perforoaza cele doua gauri cu un creion ca si in imaginea de mai jos rezultand astfel semnele necesare pentru montajul piesei (TU). (**detaliu 2**)

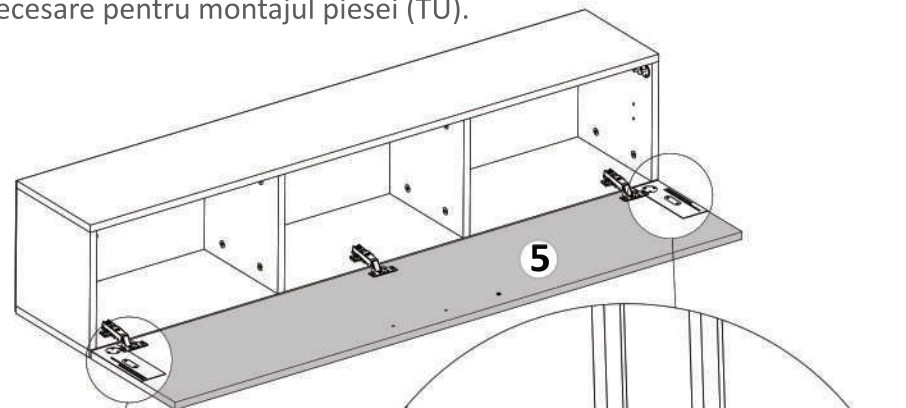

Atentie!
Linia ingrosata indica
cantul. Respectati exact
pozitia sablonului din
imagine.

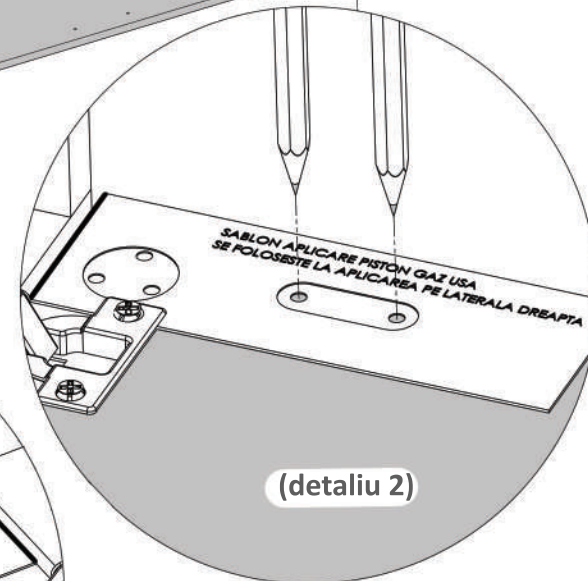
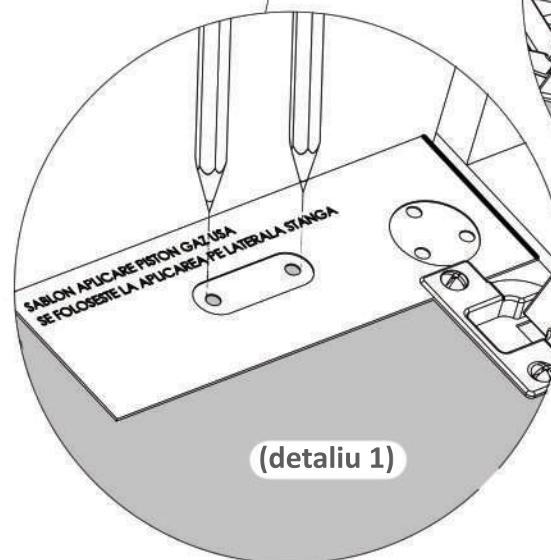

Se pozitioneaza sablonul de hartie cu inscriptia (**Sablon Aplicare Piston Gaz Usa - Se Foloseste la Aplicarea pe Laterala Stanga**) pe placa (5) si se perforoaza cele doua gauri cu un creion ca si in imaginea de mai jos rezultand astfel semnele necesare pentru montajul piesei (TU). (**detaliu 1**)